

[More Info](#) | [Instructions](#) | [Get Quote](#)

4-20mA User Guide

Water Level Temperature Sensor

August 26, 2024



Solinst[®]

1 Introduction	5
1.1 WLTS 4-20mA Interface Overview	5
1.2 WLTS 4-20mA System Components	6
1.3 Sensor Overview & Measurement Parameters	7
1.3.1 Absolute Level	7
1.3.2 Vented (Gauge) Level	7
1.3.3 Temperature	8
1.4 Communication/Vented Cables	8
1.4.1 Communication Cable Connections	9
1.5 WLTS Current Loop Adaptor	10
1.5.1 WLTS Current Loop Adaptor Connections	11
1.5.2 Current Loop Adaptor Tri-colour LED Indications	13
2.1 Communicating with the WLTS PC Software Utility	14
2.2 Programming the Water Level Temperature Sensor	16
2.3 WLTS Current Loop Adaptor Diagnostics	19
3 4-20mA Wiring Setup and Installation	20
3.1 4-20mA Wiring Connection	20
3.2 Installation	21
3.2.1 Installation in a 2" Well	23
3.2.2 Biofouling Conditions	25
4 WLTS 4-20mA Operation	26
4.1 4-2 mA Current Calculations	26
5 Maintenance	27
5.1 General Maintenance	27
5.1.1 Sensor Maintenance	27
5.1.1.1 Changing or Updating WLTS	28
5.1.2 Communication/Vented Cable Maintenance	28
5.2 Firmware Updates	29

1 Introduction

This User Guide focuses on the Solinst Model 301 Water Level Temperature Sensor (WLTS) for use as a sensor in a 4-20mA set up. Configuration, communication, installation and specifications are included.

4-20mA (4 to 20 MilliAmp) is a point-to-point or multi-drop circuit mainly used in the process automation field to transmit signals from devices and sensors in the field to a controller. It sends an analog signal from 4 to 20 mA that represents 0 to 100% of some process variable. In the case of the WLTS, the variables are water level (pressure) and temperature.

1.1 WLTS 4-20mA Interface Overview

The WLTS Current Loop Adaptor reads temperature and pressure values from a connected WLTS, converting to two channels of 4-20mA current outputs.

To connect the WLTS to the user supplied equipment, you must ensure correct wire-to-wire connection, including a continuous external power supply to the WLTS Current Loop Adaptor. Power supplied must be between 8.5V and 36V DC. The WLTS connects to a Communication Cable (vented or non) which connects to the WLTS Current Loop Adaptor. The WLTS Current Loop Adaptor is then connected to the user supplied equipment.

A simple PC Software Utility is used to configure the WLTS. The WLTS must be set with an Address of 1, Baud Rate of 19,200, Even Parity and 1 Stop bit. The Software Utility is also used to perform diagnostics on the WLTS and the WLTS Current Loop Adaptor.

1.2 WLTS 4-20mA System Components

The Solinst Model 301 Water Level Temperature Sensor requires the following components to complete a 4-20mA monitoring system:

- Sensor (WLTS)
- Communication/Vented Cable
- WLTS Current Loop Adaptor
- USB-A Programming Cable
- WLTS Software Utility (free download on solinst.com)
- User supplied equipment

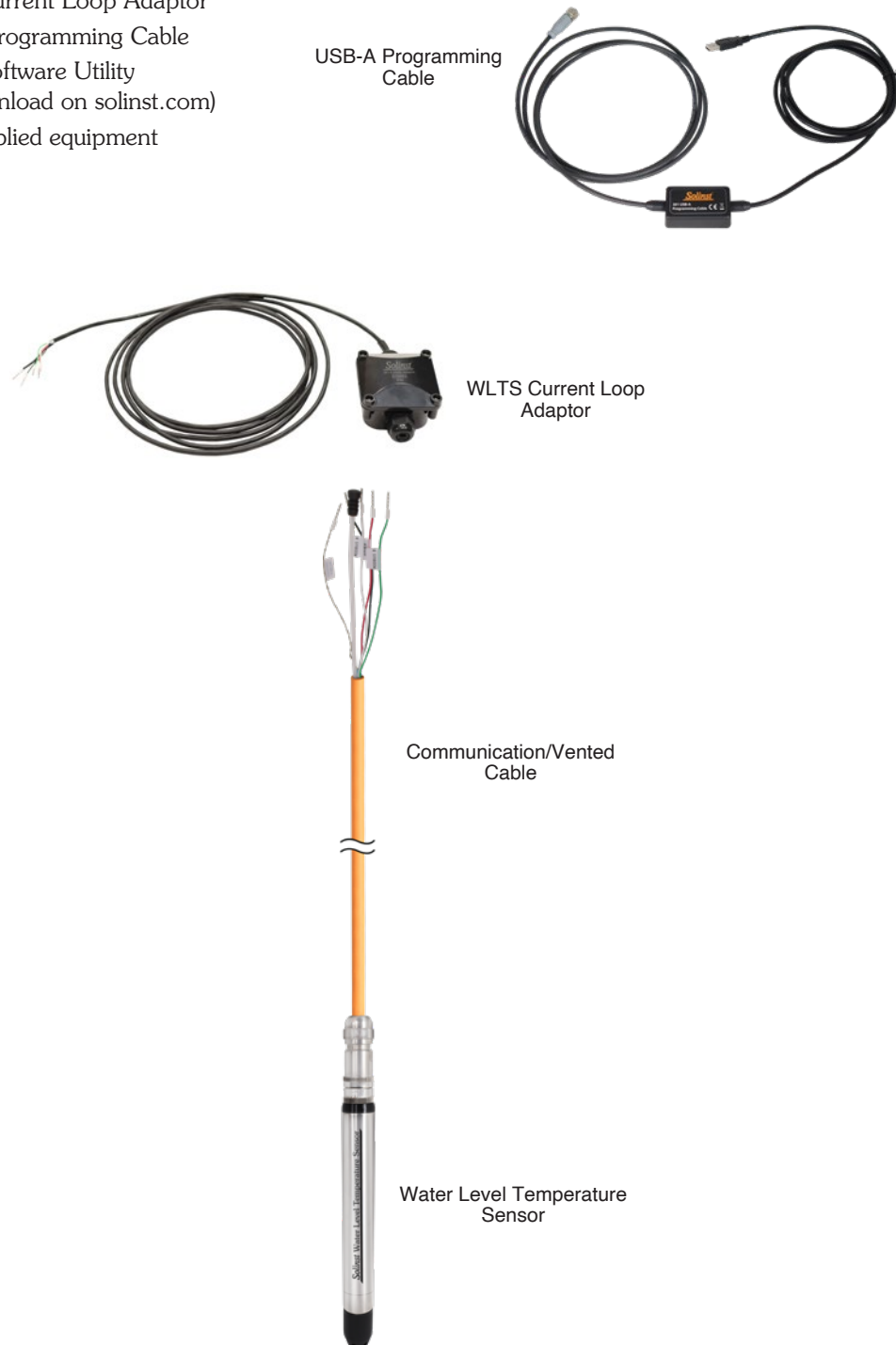

Figure 1-1 WLTS 4-20mA System Components

1.3 Sensor Overview & Measurement Parameters

The Solinst Water Level Temperature Sensor is a compact, all-in-one submersible hydrostatic level transmitter that provides continuous, accurate water level and temperature readings for a wide variety of applications.

The durable water level pressure sensor provides 0.05% FS accuracy with automatically temperature compensated readings. There are six pressure ranges to choose from (5-200 m), with options for absolute and vented (gauge) pressure sensor setups.

Water Level Temperature Sensor Specifications

Level Sensor:	Piezoresistive Silicon with Hastelloy® sensor (Absolute or Gauge)
Ranges (metres):	Absolute: M5, M10, M20, M30, M100, M200 Gauge: M5, M10, M20
Accuracy:	± 0.05% FS
Resolution:	0.01% FS
Normalization:	Automatic Temperature Compensation
Temp. Comp. Range:	0°C to 50°C
Temperature Sensor:	Platinum Resistance Temperature Detector (RTD)
Operating Temperature:	-20°C to 80°C
Temp. Sensor Accuracy:	± 0.05°C
Temp. Sensor Resolution:	0.01°C
Response Time:	1~2 minutes
Communication:	Digital communications – Modbus and SDI-12 Analog output – 4-20mA (add-on Adaptor)
Interface Connector:	4-Conductor
Power Consumption:	Inrush current at start up <50mA, max 2mA in idle, 10mA while reading sensor
Voltage:	9 to 36V
Size:	22 mm x 192 mm (7/8" x 7.55")
Weight:	173 grams (6.1 ounces)
Wetted Materials:	Delrin®, Viton®, 316L stainless steel, Hastelloy, Polyurethane (TPU boot)

Table 1-1 WLTS Technical Specifications

Note: The Model number (e.g. M5) refers to the maximum depth of submergence in meters below water, for that device.

1.3.1 Absolute Level

When submerged, absolute pressure sensors measure total pressure – the pressure of air plus water column above their zero point. The actual pressure of just water above the sensor is obtained by subtracting barometric pressure from the total pressure.

1.3.2 Vented (Gauge) Level

When submerged, vented pressure sensors detect both water and barometric pressure. However, a vent tube to surface allows barometric effects on the pressure sensor to be eliminated. Therefore, they provide readings of the actual pressure of just water above the pressure sensor zero point.

1.3.3 Temperature

The WLTS records temperature compensated water levels. A Platinum Resistance Temperature Detector is used to accurately compensate for temperature changes within the range of 0°C to +50°C.

1.4 Communication/Vented Cables

Communication Cables contain power and communication wires, as well as a vent tube running the length of the cable for the vented sensors. The vent tube and wires are jacketed in polyurethane, providing durability and protection. The cable is 8 mm (0.320") in diameter, while the connectors are 20 mm (0.790") in diameter.

Note: The Vented Communication Cables have a vent tube to surface with a Gore vent cap to ensure airflow through, while preventing moisture from entering the tube.



Non-Vented Communication Cable



Vented Communication Cable

Figure 1-2 Communication/Vented Cables

Communication Cable Specifications

Wetted Materials:	Polyurethane, Nickel plated Brass, Viton
Diameter:	Cable: 8 mm (0.32") Connector: 20 mm (0.79")
Lengths:	Up to 300 m (vented and non-vented)
Max. Bend Radius:	25 mm (1")
Operating Temperature:	-20°C to 80°C
Vent Tube Moisture Protection:	Built-in hydrophobic filters at sensor connection and plug at surface

Table 1-2 Communication Cable Specifications

1.4.1 Communication Cable Connections

To connect the Communication/Vented Cable to the WLTS, line up the pin and socket. Gently push the connections together and twist slightly until you feel/hear a small click when the properly aligned connection is made. **Only hand-tighten the coupling** while holding the cable still. Tighten the coupling until it seats.

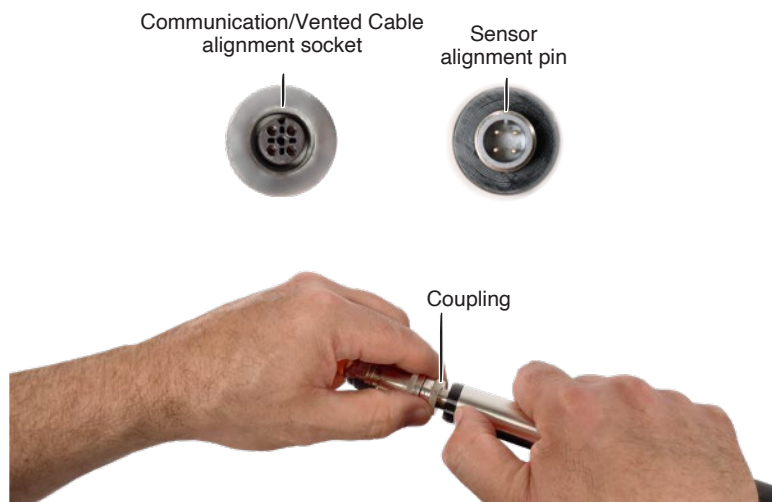

Figure 1-3 Connecting Communication/Vented Cable

1.5 WLTS Current Loop Adaptor

The WLTS Current Loop Adaptor reads temperature and pressure values from a connected WLTS, converting to two channels of 4-20 mA current outputs.

The WLTS Current Loop Adaptor is rated IP 65 (dust-proof, water-resistant, can not be submerged). It is vented, with a Gore filter where it is open to the atmosphere as a moisture barrier. An LED indicates operation status or error. The cable lead to connect to your user supplied equipment is 3 m (10 ft) in length.

There are 3 operation modes for the WLTS Current Loop Adaptor. The slide switch (SW S1) is used to set the mode. Each of these modes will be discussed in more detail in this User Guide.

SW=1, User Operation Mode

SW=2, WLTS Configuration Mode

SW=3, WLTS Current Loop Adaptor Configuration Mode

Power to the WLTS Current Loop Adaptor must be turned off when switching between modes.

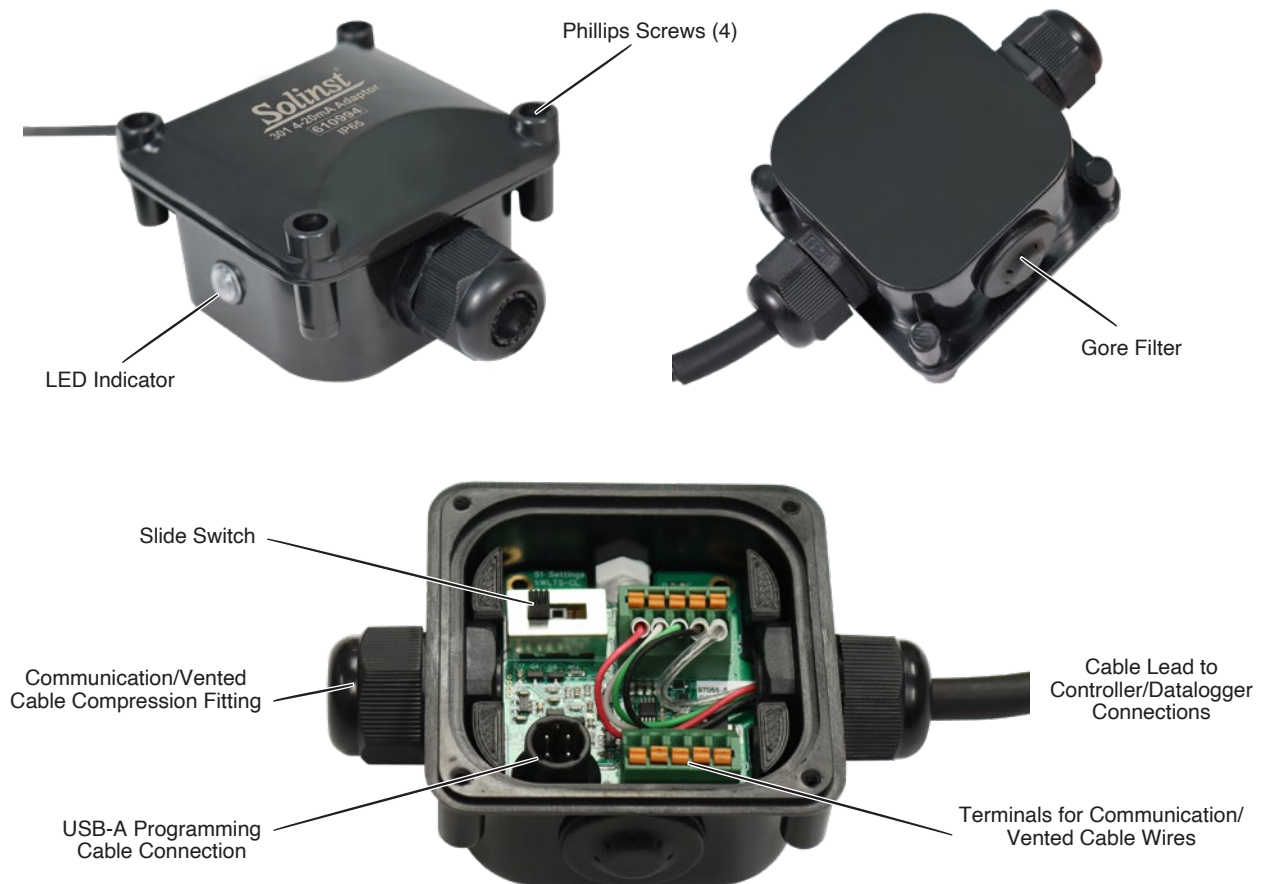

Figure 1-4 WLTS Current Loop Adaptor – External and Internal Views

1.5.1 WLTS Current Loop Adaptor Connections

To connect the WLTS to the Current Loop Adaptor, it must first be connected to the Communication/Vented Cable (see Section 1.4.1), then the Communication/Vented Cable is connected to the WLTS Current Loop Adaptor.

- 1) To connect the Cable to the Adaptor, first, unscrew and remove the compression fitting nut from the Adaptor.
- 2) Use a Phillips screwdriver to remove the four screws and remove the cover of the Adaptor.
- 3) Thread the wire leads (and vent tube for vented versions) of the Cable through the compression fitting nut, then thread them through the opening in the Adaptor.

Note: In order to fit all of the wiring inside the WLTS Current Loop Adaptor, you may need to put the vent tube underneath the circuit board.

- 4) Attach the wire leads to the push connect fittings of the WLTS terminals on the circuit board of the Adaptor. See the wiring diagram for the correct wire connections.
- 5) Pull the Cable so the start of the orange jacketed portion is in the opening in the Adaptor.
- 6) Slide the compression fitting nut up the Cable and tighten it back onto the Adaptor and Cable.
- 7) Use the four screws to reconnect the cover of the Adaptor.

Note: If configuring the WLTS, then the cover can be left off for access to the USB-A Programming Cable connector.





Figure 1-5 Connecting to the WLTS Current Loop Adaptor

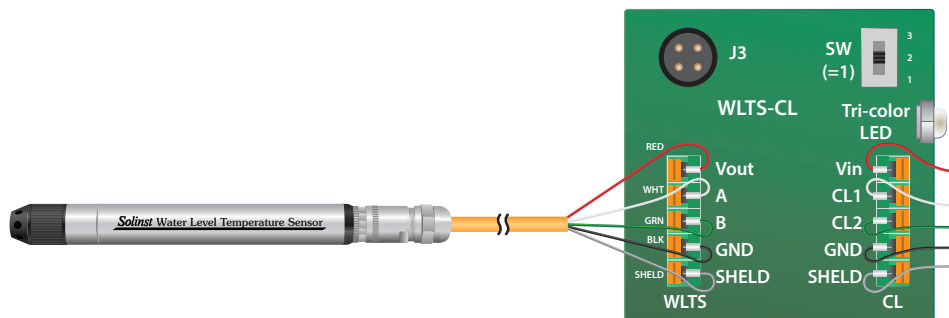

Figure 1-6 WLTS Wiring Connection to WLTS Current Loop Adaptor

1.5.2 Current Loop Adaptor Tri-colour LED Indications

The Tri-colour LED (red, green and blue) is used to indicate the WLTS Current Loop Adaptor status or error.

During each WLTS Current Loop Adaptor power up, the LED will blink each colour as a self-test.

Red LED:

When an error occurs in User Operation Mode (SW=1), the red LED will blink to indicate error code information:

- 1 blink – supply power is out of range of 8.5–36V
 - Check supply voltage or wire connections
- 2 blinks – WLTS communication failed
 - Check SW position, should be SW=1
 - Check for WLTS wire connections to WLTS Current Loop Adaptor (Section 1.5.1)
 - Check whether WLTS is set to “Use Current Loop Adaptor” (Modbus interface, Address=1, Baud Rate=19200 bps, Even Parity, 1 Stop bit) in the WLTS PC Software Utility (Section 2.2)
 - The WLTS may not be working properly, contact Solinst
- 3 blinks – received current-loop value for CL1 (temperature) is out of range of 3~21 mA
 - Check the WLTS temperature value directly read out using the WLTS PC Software Utility (see Section 2.2)
- 4 blinks – received current-loop value for CL2 (pressure) is out of range of 3~21 mA
 - Check the WLTS pressure value directly read out using the WLTS PC Software Utility (see Section 2.2)
- 5 blinks – WLTS Current Loop Adaptor internal memory checksum error
 - Re-cycle the power supply, if still occurs, contact Solinst
- 6 blinks – WLTS Current Loop Adaptor on board temperature sensor communication failed
 - Re-cycle the power supply, if still occurs, contact Solinst

The error information can also be read out using the WLTS PC Software Utility. See Section 2.3.

Green LED

- A solid green LED indicates that the WLTS Current Loop Adaptor is in Configuration Mode (for WLTS or WLTS Current Loop Adaptor configuration)
- Green LED Blinking – indicates that the WLTS Current Loop Adaptor is receiving/sending a data transmission

Blue LED

- A solid blue LED indicates that the WLTS Current Loop Adaptor is in firmware upgrade mode
- Blue LED blinking – indicates that WLTS Current Loop Adaptor is in bootloader mode receiving/sending a data transmission

2 WLTS Software Utility

The WLTS PC Software Utility is a simple tool for configuring settings and measurement parameters for the Water Level Temperature Sensor. Download the newest version of the WLTS Software Utility by visiting: <https://downloads.solinst.com>

Note: The Firmware Upgrade Utility is downloaded along with the WLTS PC Software Utility. See Section 5.2.

The following are the minimal hardware and software requirements for installation and operation:

Hardware	Software
Processor: 1 GHz or faster processor or SoC	OS: Windows 10 or 11
RAM: 1 GB for 32-bit or 2 GB for 64-bit	
Hard disk space: 128 MB	
Display: 800 x 600	
Ports: USB	

2.1 Communicating with the WLTS PC Software Utility

The WLTS Utility is Windows®-based, and is therefore used with a desktop or laptop PC.

To communicate with the PC, the WLTS is connected to the WLTS Current Loop Adaptor (Sections 1.4.1 and 1.5.1) and the Adaptor connected to the PC using the supplied USB-A Programming Cable.

- 1) Before connecting the USB-A Programming Cable to the PC, the switch on the WLTS Current Loop Adaptor should be in the SW=2 (middle) position. This will allow configuration of the WLTS using the Software Utility.
- 2) To connect the USB-A Programming Cable to the WLTS Current Loop Adaptor, if not done already, remove the cover of the Adaptor by unscrewing the four Phillips screws.
- 3) Line up the alignment pin on the Adaptor connection with the socket in the USB-A Programming Cable. Gently push the connections together and twist slightly until you feel/hear a small click when the properly aligned connection is made. **Only tighten the coupling** while holding the cable still. Tighten the coupling until it seats.



Figure 2-1 Connecting the USB-A Programming Cable

- 4) Plug the USB-A Programming Cable into your computer. Upon power-up, the WLTS Current Loop Adaptor performs a self-test while the tri-color LED blinks blue, red, and stays on at green.



Figure 2-2 WLTS PC Software Utility Communication

2.2 Programming the Water Level Temperature Sensor

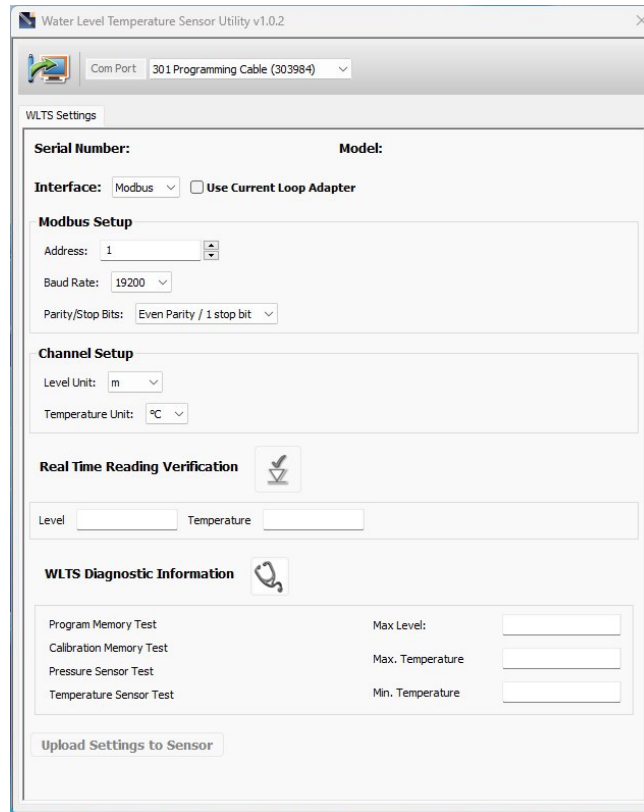



Figure 2-3 WLTS Utility

With the switch on the WLTS Current Loop Adaptor in the SW=2 (middle) position, then the USB-A Programming Cable connected to the PC, start the WLTS Software Utility. Select the appropriate Com Port for the connected WLTS from the drop-down menu.

Click the 'Retrieve Settings' icon . This will retrieve and display the current programmed settings for the connected WLTS, as well as the serial number, firmware version, and model.

Note: The Model number (e.g. M5) refers to the maximum depth of submergence in meters below water, for that device. The 'A' indicates an absolute sensor, while a 'V' indicates a vented sensor.

Select Modbus from the Interface drop-down. Use the check box to select, "Use Current Loop Adaptor".

In the Modbus Setup section, the settings must be: Address of 1, Baud Rate of 19,200, and Even Parity/1 stop bit. (These can not be adjusted once the "Use Current Loop Adaptor" check box is selected.)

Note: Without setting a specific address or Baud rate, the WLTS will power up with a default device address of 1, Baud rate of 19,200, even parity and 1 stop bit.

The units that the WLTS measures in for 4-20mA operation are psi and °C, as default.

For vented sensors, you can also perform a "Vented Sensor Zero" in air. Click Zero, you will receive a confirmation that the sensor has been zeroed. Click OK.

The parameters that were changed will be indicated by a blue highlight. When finished, click Upload Settings To Sensor. You will receive a confirmation message that the settings were uploaded. Click OK.

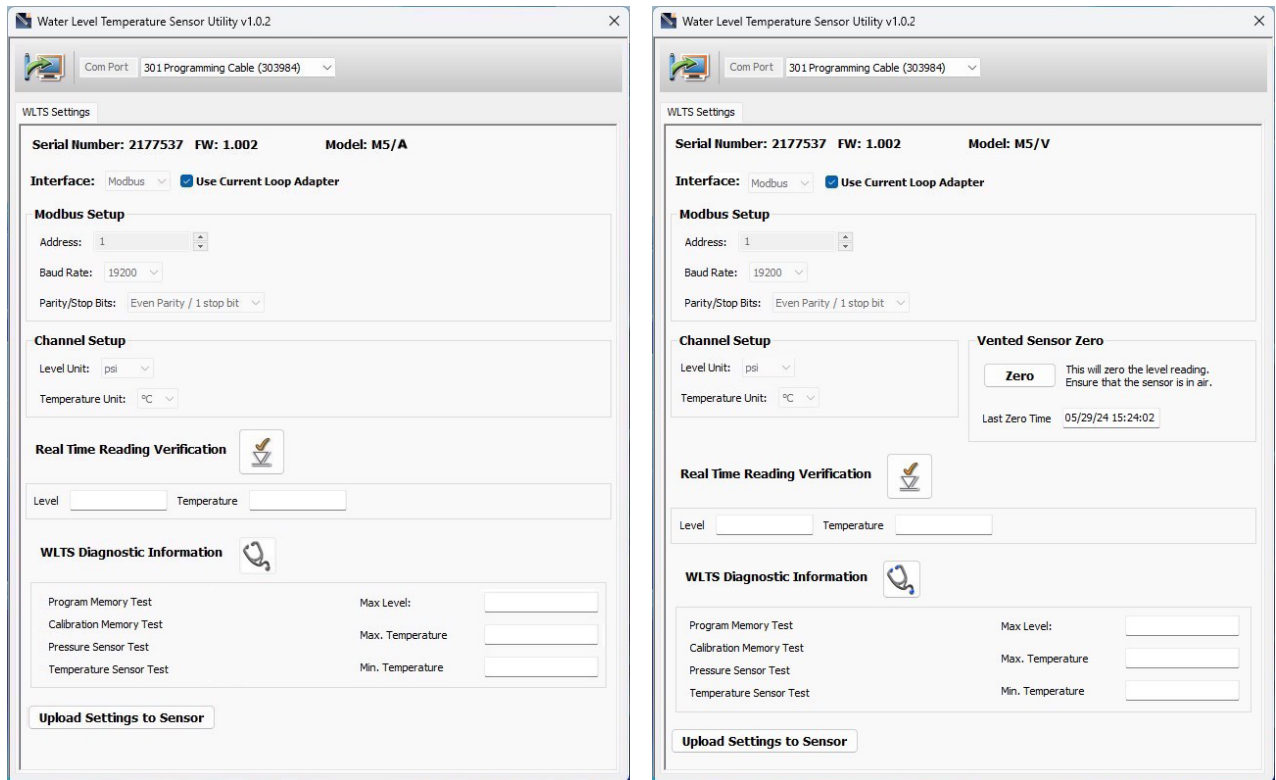



Figure 2-4 WLTS Settings – Absolute and Vented

To test that the Sensor is reading correctly, you can click the 'Real Time Reading Verification' icon  to obtain real-time readings from the Sensor.

If further Diagnostic Information is required, click the 'WLTS Diagnostics Information' icon  to perform a series of tests (Memory and Sensor) and obtain Level and Temperature information that may be helpful when troubleshooting any issues. Take a screenshot of this information to share for troubleshooting support.

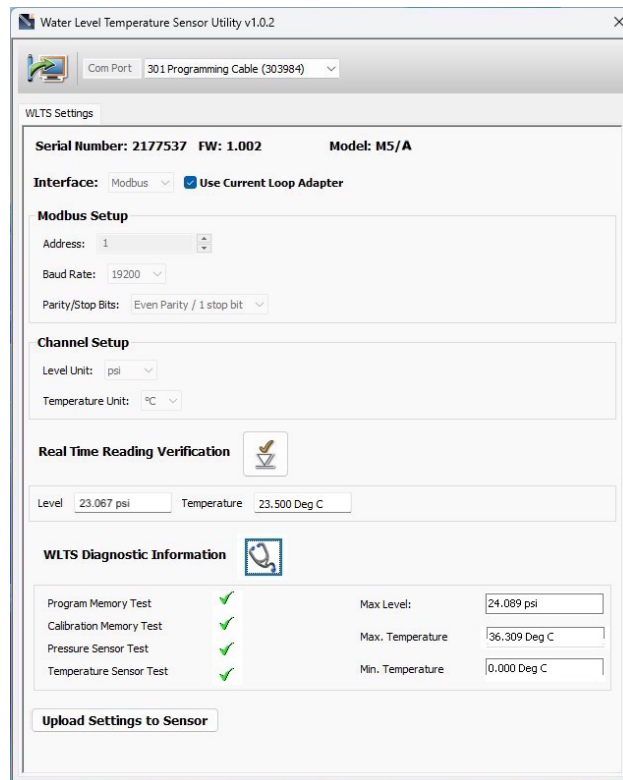

Figure 2-5 WLTS Diagnostic Information

2.3 WLTS Current Loop Adaptor Diagnostics

The WLTS PC Software Utility can be used to perform diagnostics on the WLTS Current Loop Adaptor.

To communicate with the WLTS Current Loop Adaptor, the switch must be in the SW=3 (third) position. **The modes should only be switched when there is no power applied to the WLTS Current Loop Adaptor.**

See Section 2.1 for proper connection of the USB-A Programming Cable to the connection on the WLTS Current Loop Adaptor circuit board.

Plug the USB-A Programming Cable into your computer. Upon power-up, the WLTS Current Loop Adaptor performs a self-test while the tri-color LED blinks blue, red, and stays on at green.

Start the WLTS Software Utility. Select the appropriate Com Port for the connected WLTS Current Loop Adaptor from the drop-down menu.

Click the 'Retrieve Settings' icon . This will retrieve and display the information for the connected WLTS Current Loop Adaptor, including the serial number and firmware version.

To test that the Sensor is reading correctly, you can click the 'Real Time Reading Verification' icon  to obtain real-time readings.

Click the 'WLTS Diagnostics Information' icon  to perform a series of tests to obtain information that may be helpful when troubleshooting any issues. Take a screenshot of this information to share for troubleshooting support.

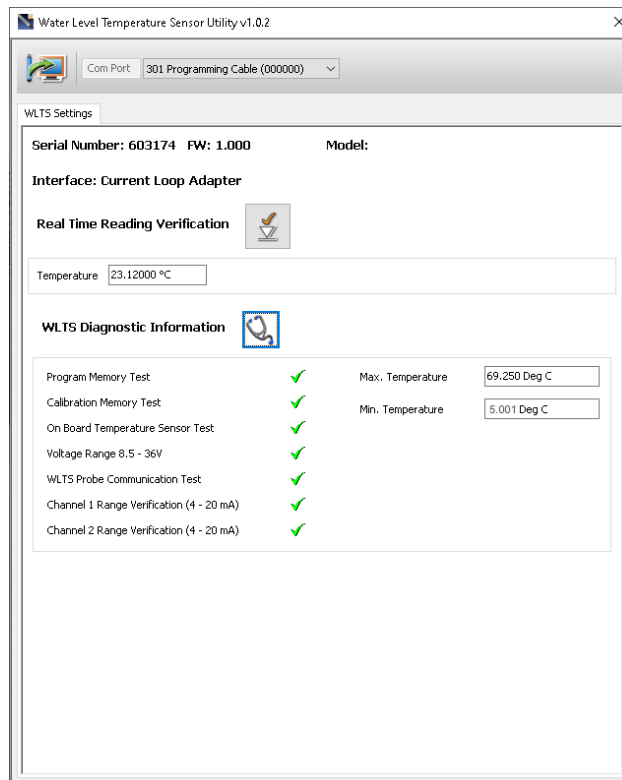

Figure 2-6 WLTS Current Loop Adaptor Diagnostic Information

3 4-20mA Wiring Setup and Installation

With the WLTS connected to the Communication/Vented Cable (see Section 1.4.1) and the Cable connected to the WLTS Current Loop Adaptor (see Section 1.5.1), refer to the wiring diagrams below for correct connection of the WLTS Current Loop Adaptor to the user supplied equipment, including external power (8.5–36V).

3.1 4-20mA Wiring Connection

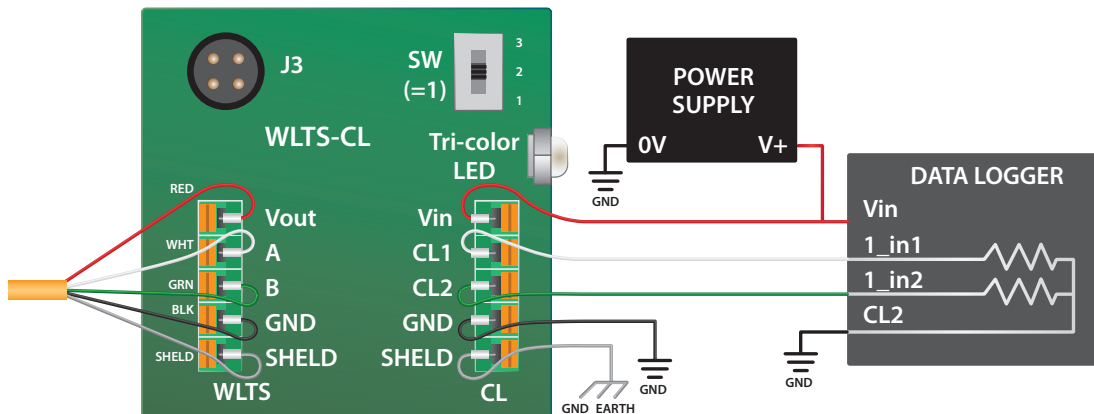
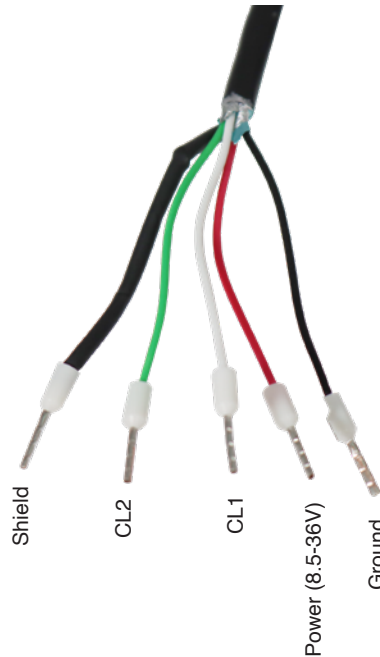

Figure 3-1 4-20mA Wiring Overview

3.2 Installation

It is recommended that the WLTS be installed in a vertical orientation. However, inclined or horizontal installation is acceptable. The pressure sensor measurement line (zero point) is indicated by the machined line around the sensor body.

The pressure transducer is oriented in a plane normal to the long axis of the body, and detects pressure directed along the plane of the long axis. In vertical orientations, the sensor detects pressure above the pressure transducer line. In non-vertical orientations, the pressure zero point is proportional to the angle of inclination.

Before Deployment, make sure you do the following:

- Program your WLTS, using the WLTS Utility, with the correct settings
- Determine deployment depth to ensure the WLTS does not touch the bottom of a tank, well, etc. (avoid submergence in sediment).

Note: The WLTS can withstand over-pressurization of 2 times the intended range, e.g. a Model M10 can accommodate a fluctuation of 20 meters or 60 feet and still record pressure. However, over-range accuracy is not guaranteed.

- Determine the minimum and maximum expected water levels, as the WLTS must remain submerged for the entire monitoring period, without over-ranging the pressure sensor.

Note: The length of the Communication/Vented Cable should not be assumed as the deployment depth, as there may be some slack in the cable.

- Use a Solinst Model 101 or 102 Water Level Meter to take a manual depth to water measurement that will be used to verify WLTS readings.

Note: It is recommended to take a manual water level measurement before installing a WLTS, shortly after installation, periodically during your monitoring interval, and at the end of your measurement period. Use these measurements to verify WLTS readings, and for data adjustments later on. Ensure you take manual readings as close in time as possible to a scheduled WLTS reading.

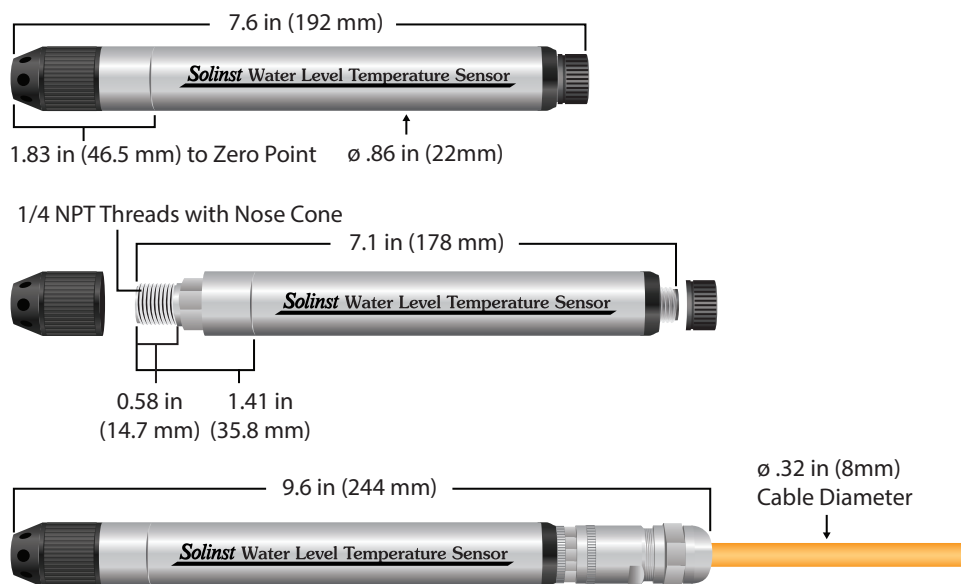

Figure 3-2 Water Level Temperature Sensor Dimensions

Deployment

- The WLTS is designed to be conveniently installed in a number of applications, as long as proper precautions and recommendations are followed.
- The nose cone of the Sensor can be removed to make use of the 1/4" NPTM threaded connection.
- Do not drop the WLTS into the water, carefully lower it into place. Avoid installing in areas where "water hammer" or hydraulic jump" (very sudden, large increases in pressure) may occur.
- Be careful not to nick or bend the Vented Cable during installation (use a maximum 1" (25 mm) bend radius as a precaution).

After Deployment, make sure you do the following:

- Take a manual depth to water measurement after the WLTS has stabilized (approximately 10 minutes).
- Take another manual depth to water measurement just before removing the WLTS.

3.2.1 Installation in a 2" Well

Solinst offers an optional Support Hanger Bracket and a 2" Well Cap Assembly, which consists of an insert, well cap base and well cap.

The 2" Well Cap Assembly insert has two openings which can optionally be used to install the Communication Cable. The second opening can be used to take manual water level measurements while the Water Level Temperature Sensor is recording down-well. When the openings are not in use, two red plugs are supplied with the assembly.

Note: A third 0.7" ID access hole allows additional monitoring equipment in the well, such as a Water Level Meter for manual field measurements.

Note: To accommodate 4" wells, a separate Adaptor is available for use with the 2" well cap base.



Figure 3-3 2" Well Cap Assembly, Adaptor, and Support Hanger Bracket

The following steps provide some guidance on how to install the Water Level Temperature Sensor using the Support Hanger Bracket and 2" Well Cap Assembly:



1. Slide the well cap base onto the well casing. Do not secure it at this point.



2. Place the Support Hanger Bracket in the well cap base so it seats on the shoulder in the base. Place the insert into the well cap base.

Note: There are three holes in the top of the Support Hanger Bracket that can be used to secure it in the well cap base with screws.

3. Remove one of the red plugs from the insert. Lower the WLTS connected to the Communication Cable through the opening and down the well until the wires at the top of the cable are above the insert. Remove the other red plug from the insert and take a manual depth to water measurement for your records.

4. Lift the well cap base with Support Hanger Bracket and insert from the well casing. Wrap the Communication Cable around the Support Hanger Bracket and slide into the cutouts to secure the cable to the bracket.

Note: The holes in the bracket can accommodate twist ties or zip ties to secure the cable to the bracket if desired.



5. Lower the well cap assembly back onto the well casing. Secure the well cap base to the well casing if desired. Install the well cap when the WLTS is not in use.



Figure 3-4 Biofoul Screen

3.2.2 Biofouling Conditions

Biofouling is the unwanted buildup of microorganisms, plants, algae, or organisms such as barnacles and muscles on a wetted surface. When a Water Level Temperature Sensor is deployed for an extended period of time, especially in a saltwater environment, there is the risk of biofouling. Biofouling on the pressure sensor can compromise the accuracy of the measurements.

A Solinst Biofoul Screen can be used to protect the WLTS from biofouling. The copper-coiled Delrin screen naturally reduces biofouling, and lengthens the time a WLTS can be deployed before maintenance is required. The Biofoul Screen simply slips onto the sensor end of the WLTS where it is held in place with its compression fitting. It allows water to freely enter the pressure transducer inlets. It is replaced as required.

4 WLTS 4-20mA Operation

Once the Water Level Temperature Sensor has been installed and powered up, the WLTS Current Loop Adaptor will send a request to the WLTS.

Note: When powering up, The WLTS Current Loop Adaptor performs a self-test while the tri-color LED blinks blue, red, and green.

The WLTS measures temperature and pressure values and sends them back to the WLTS Adaptor.

The WLTS Current Loop Adaptor outputs the corresponding 4-20mA currents to the (CL1) Temperature and (CL2) Pressure inputs of the user supplied equipment (datalogger, controller, etc.).

During communication, the WLTS Current Loop Adaptor LED will blink green twice to indicate data is being sent and received.

If there is an error, the LED will blink red. Refer to Section 1.5.2 for a description of the error.

4.1 4-2 mA Current Calculations

Temperature value to current calculation:

Temperature Range	Current Output	Formula
0 ~50°C	4~20mA	$I = (t - 0^{\circ}\text{C}) / (50^{\circ}\text{C}) \cdot 16\text{mA} + 4\text{mA}$

Pressure value to current calculation:

Pressure Range	Current Output	Formula
Pmin ~ Pmax psi	4~20mA	$I = (p - P_{\text{min}} \text{ psi}) / (P_{\text{max}} \text{ psi}) \cdot 16\text{mA} + 4\text{mA}$

WLTS Model		Pmin (psi)	Pmax (psi)
Vented Sensor	M5/V	0	23.0
	M10/V	0	30.5
	M20/V	0	45.5
Absolute Sensor	M5/A	0	23.0
	M10/A	0	30.5
	M20/A	0	45.5
	M30/A	0	60.5
	M100/A	0	165.5
	M200/A	0	295.5

5 Maintenance

5.1 General Maintenance

As with any monitoring project, you should select the proper equipment and determine a maintenance schedule based on the environment specific to your application.

For the WLTS, this means selecting the appropriate pressure range, ensuring the monitoring temperatures are within the instruments specifications, and making sure the wetted materials are compatible with site chemistry. Simple maintenance tips include:

- Clean the connections to ensure a proper seal. A cotton swab can be used to clear any moisture, or debris from the connectors.
- Keep the dust caps on all of the connections, when not in use.
- Store the WLTS in its case, and the Communication/Vented Cable on its spool when not in use.
- Clean the WLTS as required.

5.1.1 Sensor Maintenance

To ensure the vent tube remains dry, the gauge WLTS contains a permanent desiccant and hydrophobic membrane at the connection to the Vented Cable—there is no need to replace them.

Sensor maintenance consists of cleaning the outside housing, the circulation holes in the nose cone and the NPT threading. The required frequency of cleaning is dependent on several aspects of the monitored water quality. In freshwater with good to excellent water quality, the cleaning requirements will be very minimal; amounting to a seasonal or even annual maintenance inspection.

In most cases cleaning can be accomplished by rinsing the sensor and using mild, non-residual, non-abrasive household cleaners with a very soft-plastic, bristled, pipe-cleaner type brush. Do not insert any object through the sensor end.

In some cases simple cleaners are insufficient to properly clean the sensor. Several commonly occurring water conditions require specific maintenance methods. These include hard water, high suspended solids loading, biological or chemical fouling and salt or brackish water conditions.

Hard water monitoring can result in the precipitation of calcium and magnesium deposits on the pressure transducer as well as other components of the sensor. These deposits can be safely dissolved using a diluted solution (typically $\leq 10\%$ strength) of acetic or phosphoric acid. Commercially available products for dissolving hard water scaling are also available and can be used if designed for household use. Some industrial strength hard water scaling removers are much higher strength and are not recommended for cleaning the sensor.

High suspended solids load may block the circulation ports or clog the internal pressure cell of the sensor. The potential clogging effect of solids deposition can be minimized by placing the sensor in zones of flow. To remove solids build up, rinse the sensor under a low flow of tap water until particles have been washed away.

Bacteriological or chemical fouling can be an important consideration in many ground and surface water monitoring projects. Sessile bacteria will often utilize installed instrumentation as an attachment substrate. Chemical deposit can be the result of electrical charge differential between the instrumentation of the monitored liquid or the result of biological or algal activity. Both forms of fouling can result in difficult to remove deposits on the sensor transducer, the conductivity wires and the sensor casing. To remove fouling use a diluted ($\leq 10\%$) solution of sulfuric acid. Persistent material may require soaking for several hours.

5.1.1.1 Changing or Updating WLTS

If a new WLTS is attached or you have changed the settings, ensure that the power is disconnected temporarily (30 seconds) by disconnecting the Communication/Vented Cable from the WLTS. This is so the WLTS Current Loop Adaptor will re-initialize, in order to cause the new settings to be retrieved from the WLTS.

5.1.2 Communication/Vented Cable Maintenance

Proper storage of the Communication/Vented Cable is very important. The cables are shipped with the end capped; the cap should be retained, and used to seal the connection when not in use and during periods of storage. For Vented Cables, the Gore vent cap on the end of the vent tube at surface should never be removed.

It is also recommended the Vented Cable be stored on the spool it was received on (for longer lengths). This protects the Cable and avoids the vent tube from being kinked.

Note: Before the Vented Cables are shipped, the vent tubes are blown dry with nitrogen gas, and capped, to ensure no moisture during transport.

To ensure the vent tube is dry before deployment or storage, Solinst offers a Vented Cable Blowout Fitting that allows you to blow nitrogen gas through the tube. Contact Solinst for more details.

Cleaning the connection ensures a proper seal. A cotton swab can be used to clear any moisture or debris from the connector.



5.2 Firmware Updates

The Water Level Temperature Sensor and the WLTS Current Loop Adaptor have been designed with firmware that is easy to update whenever useful new functions or other improvements become available, as with software releases.

To update the firmware, go to the Solinst Website at: <https://downloads.solinst.com> where you can sign-in or register to download the firmware upgrade file that is contained within a Zip Archive. Ensure you unzip the Archive to access the firmware *.ssf file.

Note: It is important that the communication between the PC and the sensor is not interrupted during a firmware upload, so please make sure to close any other running programs, including screen savers, and do not disconnect the sensor before the upload is finished.

To upload new firmware to a Water Level Temperature Sensor, follow these steps:

- 1) Connect the WLTS or WLTS Current Loop Adaptor to your PC using the USB-A Programming Cable (see Section 2.1 or Section 2.3).
- 2) To upgrade firmware in your WLTS, the switch on the WLTS Current Loop Adaptor must be in the SW=2 (middle) position. To upgrade the firmware in the WLTS Current Loop Adaptor, the switch must be in the SW=3 (third) position.
- 3) Open the Solinst Firmware Upgrade Utility from the shortcut created on your desktop when the WLTS Utility was downloaded. Select the Com Port that the sensor is connected to from the drop-down menu.
- 4) Click the 'Open' button , which should open a file dialog asking for the firmware file (*.ssf) to upload. Navigate to the directory where the firmware file was saved on your PC, then click on the file and click 'Open'.
- 5) Check the 'File Information' box to make sure the opened file is correct.
- 6) Click the 'Upload Firmware' button , to start the firmware upload process.
- 7) If a communication error occurs and is indicated in the 'Datalogger Status' box either before or after the "Verifying Firmware" and "Loading Firmware to Datalogger" messages, then restart the upgrade process.
- 8) If, however, a communication error occurs between the "Verifying Firmware" and the "Loading Firmware to Datalogger" messages, then please contact Solinst. You will need to give the sensor Serial Number and explain the exact positioning of the error message.

Note: When conducting a firmware upgrade, DO NOT interrupt the process prior to completion (This may take 2 to 4 minutes). Installation is not complete until a note appears at the base of the program window indicating "Firmware Update Completed".

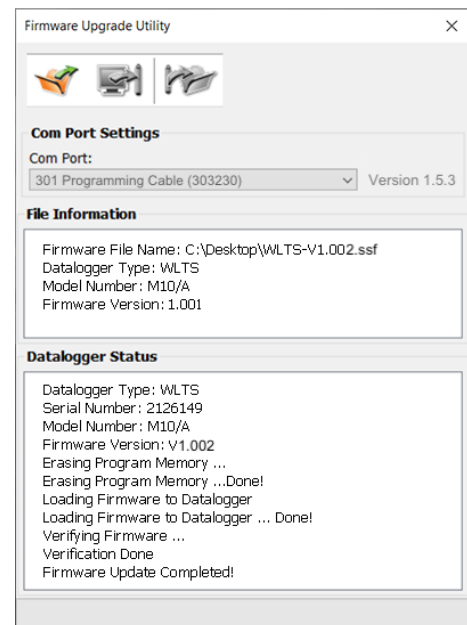

Figure 5-1 Firmware Upgrade Utility



www.solinst.com

High Quality Groundwater and Surface Water Monitoring Instrumentation

Solinst Canada Ltd., 35 Todd Road, Georgetown, ON L7G 4R8
Tel: +1 (905) 873-2255; (800) 661-2023 Fax: +1 (905) 873-1992
instruments@solinst.com

Solinst[®]