

A New Multilevel Ground Water Monitoring System Using Multichannel Tubing

by Murray D. Einarson and John A. Cherry

Abstract

A new multilevel ground water monitoring system has been developed that uses custom-extruded flexible 1.6-inch (4.1 cm) outside-diameter (O.D.) multichannel HDPE tubing (referred to as Continuous Multichannel Tubing™ or CMT) to monitor as many as seven discrete zones within a single borehole in either unconsolidated sediments or bedrock. Prior to inserting the tubing in the borehole, ports are created that allow ground water to enter six outer pie-shaped channels (nominal diameter = 0.5 inch [1.3 cm]) and a central hexagonal center channel (nominal diameter = 0.4 inch [1 cm]) at different depths, facilitating the measurement of depth-discrete piezometric heads and the collection of depth-discrete ground water samples. Sand packs and annular seals between the various monitored zones can be installed using conventional tremie methods. Alternatively, bentonite packers and prepacked sand packs have been developed that are attached to the tubing at the ground surface, facilitating precise positioning of annular seals and sand packs. Inflatable rubber packers for permanent or temporary installations in bedrock aquifers are currently undergoing site trials. Hydraulic heads are measured with conventional water-level meters or electronic pressure transducers to generate vertical profiles of hydraulic head. Ground water samples are collected using peristaltic pumps, small-diameter bailers, inertial lift pumps, or small-diameter canister samplers.

For monitoring hydrophobic organic compounds, the CMT tubing is susceptible to both positive and negative biases caused by sorption, desorption, and diffusion. These biases can be minimized by: (1) purging the channels prior to sampling, (2) collecting samples from separate 0.25-inch (0.64 cm) O.D. Teflon® sampling tubing inserted to the bottom of each sampling channel, or (3) collecting the samples downhole using sampling devices positioned next to the intake ports. More than 1000 CMT multilevel wells have been installed in North America and Europe to depths up to 260 feet (79 m) below ground surface. These wells have been installed in boreholes created in unconsolidated sediments and bedrock using a wide range of drilling equipment, including sonic, air rotary, diamond-bit coring, hollow-stem auger, and direct push. This paper presents a discussion of three field trials of the system, demonstrating its versatility and illustrating the type of depth-discrete data that can be collected with the system.

Introduction

Many investigations have shown that contaminant plumes are typically complex zones that exhibit large variations in concentration over small vertical distances. These variations are caused by spatial and temporal variability of the contaminant sources and heterogeneity of the geologic materials. In sand aquifers, large vertical concentration variability within plumes is enhanced by weak transverse vertical dispersion that preserves the variability over large travel distances (Reinhard et al. 1984; Robertson et al. 1991; van der Kamp et al. 1994). Weak dispersion has been documented during natural gradient tracer experiments in which the tracers were monitored intensively using multilevel depth-discrete samplers (Mackay et al. 1986a, 1986b; Garabedian et al. 1991; LeBlanc et al. 1994).

Conventional monitoring wells are often ineffective for discerning the details of the concentration distribution in plumes and particularly for locating the highest concentration zones

because the well screens provide water samples that are a mixture of waters of different composition from various depths (Robbins 1989; Martin-Hayden et al. 1991; Robbins and Martin-Hayden 1991). Nested monitoring wells (i.e., two or more individual wells installed to different depths in the same borehole) can yield depth-discrete samples; however, their use is discouraged because of the difficulty in installing reliable seals between the different well screens (U.S. EPA 1986). Clusters of conventional monitoring wells (i.e., closely spaced wells installed in individual boreholes but completed to different depths) are an alternative to nested wells but commonly do not monitor more than two or three depth intervals because of the economic limitation on the number of wells used in each cluster. To overcome these limitations, multilevel monitoring systems that provide water samples from many depth-discrete levels or ports in a single monitoring hole have been used, such as those described by Pickens et al. (1978), Cherry and Johnson (1982), and Black and Patton (1986).

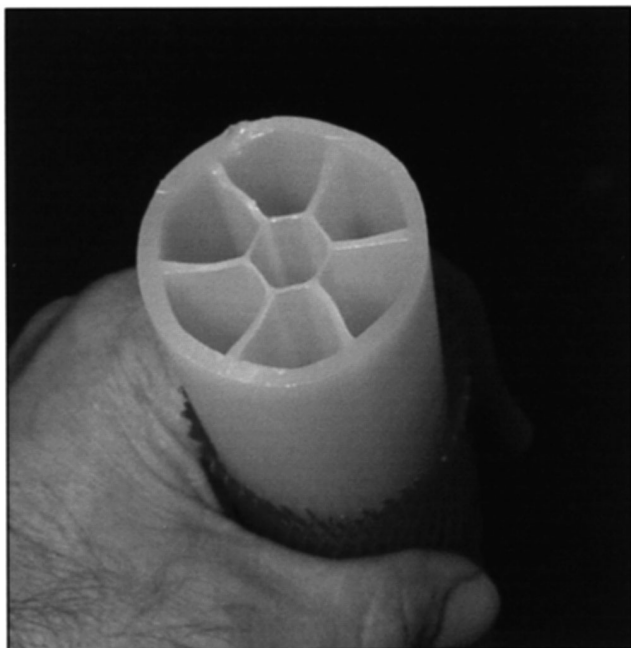

Figure 1. CMT tubing.

This paper describes a new low-cost permanent multilevel monitoring system that can be used to collect ground water samples and measure hydraulic heads from up to seven discrete zones in one borehole. The system uses a single length of custom-extruded flexible tubing, facilitating the installation of reliable annular seals between the monitoring zones using conventional well-construction methods where annular materials (e.g., sand and bentonite pellets) are added from the ground surface. Bentonite packers also have been used that allow the entire multilevel well to be constructed aboveground and then inserted into a borehole. By using the bentonite packers, seals of exact dimensions and position can be installed. A modification of the system using water-inflated rubber packers for use in rock boreholes is currently undergoing site trials.

Materials and Methods

Continuous Multichannel Tubing

The key component of the new monitoring system is custom-made, high-density polyethylene (HDPE) tubing. The 1.6-inch (4.1 cm) outside diameter (O.D.) tubing, referred to as Continuous Multichannel Tubing™ (CMT™, patent pending), is extruded with internal partitions, forming seven discrete channels within the larger tube (Figure 1). The honeycomb design creates six outer pie-shaped channels having a nominal inside diameter of ~0.5 inch (1.3 cm) and a central hexagonal channel ~0.4 inch (1 cm) in diameter. The primary advantage of the new multichannel tubing over bundles of tubes as described by Cherry et al. (1983) is that there is only one relatively large tube installed in the borehole, which simplifies the installation of annular seals placed between the tubing and the borehole wall.

The multichannel tubing can be extruded in lengths currently up to 300 feet (92 m) and is shipped in 4-foot (1.2 m) diameter coils (Figure 2). The desired length of tubing, equal to the total depth of the multilevel well, is cut from a coil, and



Figure 2. CMT tubing coil.

the well is built at the job site based on the hydrogeologic data obtained from the exploratory boring or other methods (e.g., CPT or geophysical data). Having a continuous length of tubing is a key advantage of the system because it eliminates the need for strong, watertight joints in the monitoring well. No joints exist because the tubing is one piece. This increases the reliability and reduces the cost of the monitoring system. The tubing is stiff enough to be easily handled, yet light and flexible enough to allow site workers to insert the multilevel well hand-over-hand into the borehole.

A small ridge along the outside of one of the channels facilitates identification of specific channels. The collapse and tensile strengths of the tubing have not yet been tested, but are expected to be high because of the internal honeycomb structure of the tubing.

Intake Ports and Screens

Construction of the intake ports and screens is done before the CMT is inserted into the borehole. Depth-discrete intake ports are created by drilling or cutting 0.38-inch (0.95 cm) holes through the exterior wall of the tubing into each of the channels at the desired depths. Channel 1 ports correspond to the shallowest monitoring interval; channel 2 ports are drilled further down the tubing (i.e., to monitor a deeper zone), and so forth. The central channel, channel 7, is open to the bottom of the multilevel well. In this way, the ports of the various channels are staggered both vertically and around the perimeter of the multichannel tubing. Typically, each channel is hydraulically connected to only one monitoring interval. However, the well can be constructed with two channels open to the same interval: One channel can be used for measuring water levels; the other for collecting ground water samples with a dedicated sampling pump. Because two channels are used at each depth, constructing a well this way reduces the number of intervals that can be monitored. For most of the installations performed to date, an intake interval of 4 inches (10 cm) has been created by drilling four holes 1 inch (2.5 cm) apart. The depth interval of the intake ports can be increased simply by drilling more holes.

Well screens are constructed by wrapping synthetic or stainless-steel fabric mesh completely around the tubing in the interval containing the ports (Figure 3). The mesh is secured

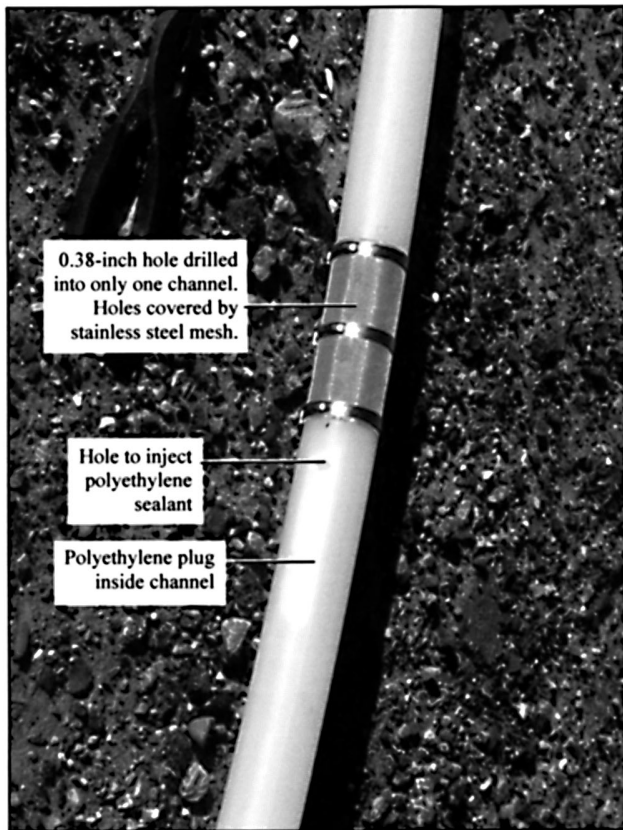

Figure 3. Typical CMT intake port.

to the tubing using stainless-steel clamps. The size of the mesh openings can be selected based on the grain-size distribution of the particular water-bearing zone being monitored. However, a 100 mesh stainless-steel screen having an open area of ~0.006 inch (0.15 mm) has been used successfully for most of the installations performed to date.

Stagnant water in the tubing below the intake ports is hydraulically isolated by plugging the channels a few inches below each intake port. This has been done by injecting a small amount of a polyethylene sealant into each channel (Figure 3). Polyethylene plugs are also injected into each of the outer six channels at the very bottom of the well. This effectively seals the various channels from just below the intake ports to the bottom of the well. (Pressure tests show that a 1-inch-long plug withstands a pressure differential of more than 80 pounds per square inch [552 Kpa; Solinst Canada Ltd. 2001]). Small vent holes are drilled directly beneath the upper polyethylene plugs (i.e., the plugs located just below the intake ports) to allow air to vent out of the sealed channels during installation. The seventh (internal) channel is open to the bottom of the well. A cap of stainless-steel mesh is attached to the bottom of the tubing to enable the central channel to be used as the deepest monitoring zone.

Installation Methods

Installation in Collapsing Sands

In loose, unconsolidated sand formations, seven-zone monitoring wells can be quickly installed by inserting the tubing (with drilled ports and well screens) into the ground through a steel drive casing and then removing the drive cas-

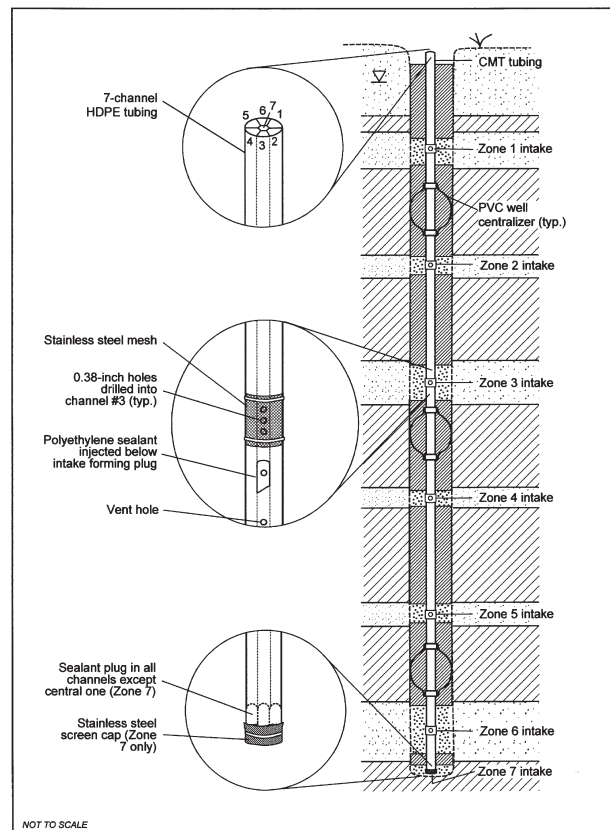

Figure 4. Installation of a CMT multilevel well where sand pack and bentonite seals are tremied from the ground surface.

ing. When the drive casing is removed, the sand will collapse around the multilevel well, restoring the original permeability of the sediments between the various monitored zones. This method of installation can be very rapid (47 20-foot [6.1 m] deep multilevel wells have been installed in two days with this method) and is particularly well suited to dual-tube direct-push (DP) sampling systems (Einarson 1995) and sonic drilling equipment (Barrow 1994). However, when used without seals between sampling ports in such cohesionless deposits, the system loses its advantage over bundles of polyethylene or Teflon tubes (such as those described by Cherry et al. [1983]), which offer more ports for more detailed depth-discrete monitoring.

Installation Using Conventional Well-Construction Techniques to Install Sand Packs and Annular Seals

In clay-rich or indurated sediments and bedrock, the borehole usually will not collapse and other methods are necessary to seal the annulus between the various intake ports. At these sites, alternating lifts of sand and bentonite have been added to the annular space from the ground surface using conventional well construction techniques (Figure 4). First, ports are created and stainless-steel screens are attached to the tubing at the ground surface, as discussed previously. Next, the CMT is lowered to the bottom of the borehole either in an open hole (if the borehole will stay open) or inside steel casing or hollow-stem augers. Alternating lifts of sand and bentonite pellets are poured into the annular space from the ground surface to specific depths according to the well design. In an open hole, materials can be added via a tremie pipe to ensure that no bridge-

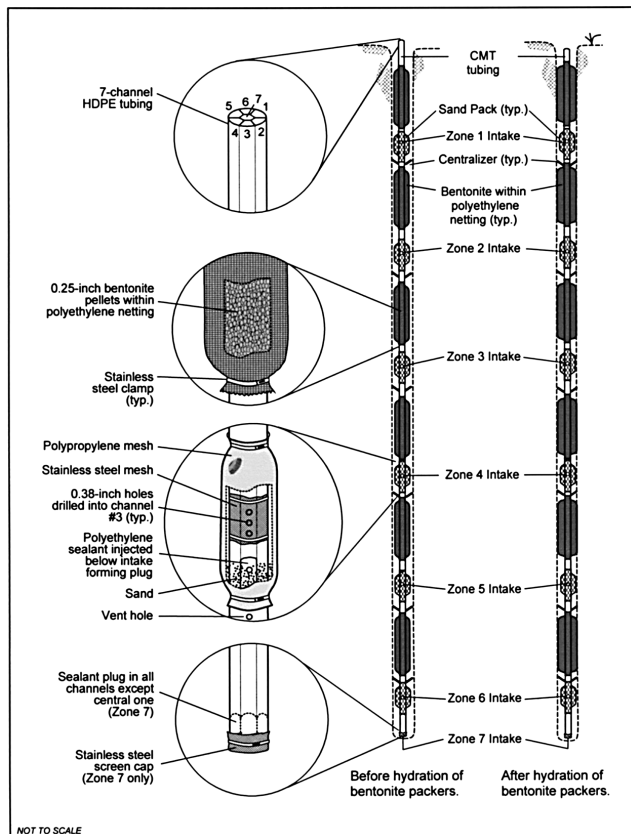

Figure 5. Installation of the CMT well with prepacked sand packs and bentonite packers.

ing occurs. In cased holes (steel drive casing or hollow-stem augers), the sand and bentonite pellets are usually poured from the surface without a tremie pipe. The casing or augers are removed incrementally as the annular materials are added. In either case, the depth of the sand and bentonite is measured frequently during construction using a weighted measuring line.

Because the tubing is flexible, closely spaced (e.g., every 15 feet [4.6 m]) steel or PVC centralizers have been attached to the CMT to ensure that the tubing is centered in the borehole during construction. The use of centralizers can be avoided by using a 2-inch (5 cm) metal or polyvinyl chloride (PVC) insertion pipe to center the CMT during well construction. The insertion pipe is placed in the borehole prior to inserting the CMT. Annular materials are poured from the surface and the insertion pipe is removed from the borehole incrementally along with the steel casing or augers (if used). Two centralizers (20 feet [6.1 m] apart) have been attached to the bottom of the insertion pipe to keep the CMT centered in the borehole during construction. In this way, the annular space between the insertion pipe and the borehole (or casing/augers) is unobstructed by centralizers, minimizing the likelihood of bridging the bentonite pellets and tangling the measuring line. For deep wells where the water table is shallow, coated bentonite pellets have been used. Coated pellets prevent the bentonite from swelling prematurely as the pellets fall through standing water. Premature hydration of the pellets can create undesirable bridging in the annulus, preventing the pellets from falling to the desired depth.



Figure 6. Stainless-steel form used to construct bentonite packers.

Installation in Noncollapsing Sediments Using Bentonite Packers and Prepacked Sand Packs

Installing seven-zone multilevel wells using the conventional well-construction techniques described requires precise placement of annular seals and sand packs, especially for shallow wells where each seal may be only a few feet thick. This degree of precision may not be possible at many sites using conventional well-construction methods where some amount of sloughing of native materials and/or overfilling of materials often occurs. Consequently, bentonite packer seals were developed that can be attached to the CMT prior to insertion into the borehole. This eliminates the need to add annular materials from the ground surface and offers greater precision in the construction of shallow multilevel wells. Sand packs can also be attached around the well screens in a similar fashion.

The bentonite packers have been constructed using commercial 0.25-inch (0.64 cm) bentonite pellets contained inside of polyethylene mesh sleeves (Figure 5). The mesh sleeves allow the ground water to freely contact and hydrate the bentonite and stretch as the bentonite swells. The bentonite packers should contain as much bentonite as possible yet be small enough to easily fit inside of the borehole.

A stainless-steel form aids in the assembly of bentonite packers and ensures a consistent diameter (Figure 6). The form is threaded over the CMT and placed inside of the polyethylene mesh sleeve. Flanges on the inside of the form ensure that the form is centered around the CMT. Bentonite pellets are then poured inside of the steel form until it is full. The form is then pulled up, leaving behind a cylinder of bentonite pellets around the multichannel tubing.



Figure 7. Bentonite packer (right) prior to insertion in a borehole. To left, bentonite packer after it has hydrated and swelled.

Openings in the mesh are sufficiently large to allow some of the bentonite to squeeze through the mesh as the bentonite swells, creating a bond with the borehole wall (Figure 7). The bentonite packers constructed to date have typically been 1 or 2 feet (31 or 61 cm) long. Annular seals of any length can be made by attaching bentonite packers to the CMT "back to back" in the entire interval where an annular seal is desired. To maximize the integrity of the annular seals, the multilevel well should be centered in the borehole. PVC well centralizers have been used to center the CMT and bentonite packers in boreholes up to 4.5 inches (11.4 cm) in diameter.

The bentonite packers constructed to date have contained enough bentonite to expand and seal an annular space up to 0.75 inch (1.9 cm). Sealing larger annular spaces requires the use of more bentonite pellets, which makes the packers deform under their own weight. Consequently, the use of this type of bentonite packer should be limited to installations where the annular space between the CMT tubing and the borehole wall is 0.75 inch (1.9 cm) or less. Also, the bentonite packers manufactured to date are easily deformed and torn during installation. For this reason, they should be limited to installations where temporary flush-threaded, thin-walled steel casing is used to keep the borehole open while the fully built CMT well is inserted. The current bentonite packers are not appropriate for installations inside of hollow-stem augers because the packers will not swell sufficiently to seal the relatively large annular space created by the auger flights.

Once all of the bentonite packers, sand packs, and centralizers have been attached to the CMT, the tubing is inserted into the steel drive casing hand-over-hand to the bottom of the borehole (Figure 8). Insertion of the tubing into a 100-foot-deep (31 m) borehole takes ~10 minutes. After the well is in place, the temporary steel casing is removed, allowing ground water to hydrate the bentonite packers. As they hydrate, the bentonite packers swell, sealing the borehole between the monitoring zones within three or four hours. More than 200 installations of the CMT multilevel system equipped with bentonite packer seals and prepacked sand packs have been successfully performed to date, including an installation to a depth of 195 feet (60 m) using a sonic drill rig.



Figure 8. Inserting a CMT multilevel well equipped with bentonite packers and prepacked sand packs.

Well Development, Measuring Hydraulic Head, Hydraulic Testing, and Collecting Ground Water Samples

Well Development

Requirements for developing the multilevel wells vary depending on the type of installation. If no foreign water is introduced to the aquifer during installation, well development can be limited to thorough purging to remove introduced fines from the borehole wall and enhance the hydraulic connection with the formation. If foreign water or other drilling fluids are used during drilling and well installation, removal of large quantities of water may be necessary.

Limited well development can be performed using small-diameter sampling pumps. However, the extraction rate of the pumps is small and extracting large volumes of water (e.g., hundreds of gallons) is not cost-effective. Also, the low extraction rates of small-diameter sampling pumps create a relatively weak hydraulic stress, resulting in a limited ability to remove introduced fines and/or smeared soil from the borehole wall, especially in large-diameter borings drilled in relatively permeable formations.

An innovative gas-lift/vacuum extraction system has been developed to simultaneously extract ground water from all seven zones. This system, which is a variation of standard air-lift well development techniques, has been used to develop 1300 gallons (4921 L) of water at a flow rate of 1.1 gallons/min (4.2 L/min) from a multilevel well where the static depth to water was 100 feet (31 m) below ground surface (bgs). The gas-lift/vacuum extraction system is described in more detail by Einarson (2001).

Measuring Hydraulic Heads

Depth to ground water measurements can be made using commercially available water level meters (e.g., well sounders). Water-level measurements >150 feet (46 m) bgs have been made inside of the CMT using a small-diameter water-level meter (Solinst Canada Ltd., Georgetown, Ontario, Canada). If continuous pressure measurements are desired, pressure transducers small enough to fit down the CMT channels (Druck Model PDCR 35D-8070) are commercially available (Solinst Canada Ltd. 2001).

Hydraulic Testing

The authors are aware of several sites where environmental consultants have performed rising- and/or falling-head tests (i.e., slug tests) in CMT wells, although the authors have not yet performed such tests themselves. The availability of small-diameter transducers connected to dataloggers facilitates the recording of rapid hydraulic responses in permeable aquifers that would not be possible with hand measurements. Calculation of formation hydraulic conductivity using conventional analytical solutions may be complicated, however, by the pie-shaped geometry of the CMT. The potential error associated with the nonradial CMT well geometry is a function of the relative difference between the sand pack and formation hydraulic conductivity, and could possibly be addressed using a skin factor applied to the analytical solution (Butler 2001). Hydraulic testing in CMT wells is the subject of ongoing research and testing by the authors and other collaborators.

Collecting Ground Water Samples

Ground water samples can be collected from the CMT multilevel system using a variety of methods including peristaltic pumps (providing that the water level is within the limits of suction lift), inertial lift pumps (e.g., Waterra® pumps [Rannie and Nadon 1985]), and small-diameter bailers. Small-diameter downhole canister samplers such as those described by Pankow et al. (1985) and Johnson et al. (1987) may also be used to collect ground water samples from the bottom of each channel directly adjacent to the intake ports. Because of the small internal diameter of the CMT channels, no commercially available submersible or bladder pumps currently exist for the system, although an innovative double-valve sampling pump is under development (Solinst Canada Ltd. 2001).

Water samples have been successfully collected from a CMT multilevel well at a flow rate of 120 mL/min using a hand-operated 0.25-inch (0.64 cm) O.D. Teflon inertial lift pump where the static depth of ground water was 100 feet (31 m) bgs. The purge volume of the internal channels is ~40 mL/foot (131 mL/m) of tubing, which minimizes the amount of purge water that needs to be removed prior to sampling.

All sampling devices can impart biases in analytical results because of the volatilization of organic contaminants, sorption/desorption of hydrophobic solutes onto/off of sample tubing, pH changes that may precipitate dissolved metals, etc. Parker (1994) offers a thorough literature review of the biases associated with various ground water sample collection methods.

Potential Chemical Biases Associated with the CMT System

Because the CMT monitoring system uses one continuous length of tubing, the tubing must be flexible enough to bend 90 degrees when it is being inserted into a borehole. This degree of flexibility requires that the system be made of polymeric tubing. A drawback of polymeric tubing as a well-construction material is that it is less resistant to sorption (adsorption and absorption) of hydrophobic organic contaminants than rigid well construction materials such as stainless steel or PVC. Chemical biases associated with polymeric tubing have been described by many authors and are therefore discussed only briefly in this paper.

Sorption/Desorption of Organic Contaminants onto/off of the Interior Walls of the CMT During Sampling

A negative sampling bias can occur if organic contaminants sorb onto the interior walls of the HDPE CMT while the water sample is pumped up from the sampling port to the ground surface. For HDPE tubing, the amount of contaminant mass lost from the sample is proportional to the residence time within the channel and the hydrophobicity of the organic solute (Hewitt 1994; Parker and Ranney 1998). Conversely, a positive bias can occur during a later sampling event if organic molecules desorb from the tubing into the subsequent ground water sample (Barcelona et al. 1985; Barker et al. 1987; Gillham and O'Hannesin 1990; Parker and Ranney 1998).

Diffusion of Organic Contaminants from the Aquifer Surrounding the CMT Well

Barker et al. (1987), Gillham (1989), and Gillham and O'Hannesin (1990) showed that in wells or piezometers constructed of polyethylene tubing, hydrophobic organic compounds can diffuse through the tubing from the aquifer into water inside the tubing in response to concentration gradients. In the case where the intake of a polyethylene well is located below a high-strength contaminant plume, hydrophobic volatile organic compounds (VOCs) detected in samples collected from the well may simply be a result of diffusion through the tubing from the shallow contaminant plume surrounding the exterior of the tubing. Such detections could lead site investigators to falsely conclude that the VOC contamination extends to a greater depth than it actually does. With the CMT system, the potential sampling bias is further complicated by the honeycomb structure of the tubing. During the time between sampling events, solutes present in one or more of the channels could diffuse into adjacent channels, resulting in the false detection of the solutes in one or more of the multilevel sampling intervals.

Leaching of Organic Compounds from HDPE Tubing and/or Polyethylene Hot-Melt Sealant

Leaching of organic compounds from the CMT well materials can result in a potential positive sampling bias. Leaching of trace organic compounds from polymer tubing has been evaluated by several researchers, including Junk et al. (1974), Curran and Tomson (1983), Barcelona et al. (1985), Parker and Ranney (1997), Parker and Ranney (1998), and Ranney and Parker (1998). Those studies indicate that polyethylene tubing, by itself, is either inert or does not impart significant amounts of common target organic compounds to water that has been in contact with the tubing. As discussed previously, however, a commercial hot-melt polyethylene adhesive (Arrow C-7 Hot-Melt Sealant, Arrow Fastener Co. Inc., Saddle Brook, New Jersey) has been used to seal the various channels below the sampling ports. The sealant is injected using a high-temperature glue gun. Leaching of trace organic compounds from the polyethylene sealant is another potential source of positive sample bias with the system. The potential bias caused by leaching of organic compounds from the polyethylene tubing and the hot-melt polyethylene sealant was investigated by performing static leaching tests on virgin materials used to construct the CMT wells. Details of the leaching tests, including

analytes and detection limits, are presented by Einarson (2001). In summary, samples of distilled water that had been in contact with virgin CMT polyethylene tubing and hardened hot-melt sealant for one week were analyzed for a comprehensive suite of VOCs using gas chromatograph/mass spectrometry (GC/MS) methods in accordance with U.S. EPA Method 8260B. No VOCs were detected in the water that had been in contact with the polyethylene; however, toluene was detected at a concentration of 25.5 $\mu\text{g/L}$ in the sample of water that had been in contact with the hot-melt sealant. Although the detection of toluene in the leachate sample suggests that there may be a systematic positive bias caused by leaching of the polyethylene sealant in the CMT wells, two years of field monitoring suggests otherwise. Only one anomalous detection of toluene has been measured in hundreds of analyses of ground water samples collected from CMT wells. The well in question is completed in a fine-grained formation that yields little water during sampling. Because the rate of recovery is so slow, it has not been possible to purge the well before sampling. Only a foot or two of ground water is typically present in the channel, and initial analyses of ground water collected from the channel two weeks after the well was installed contained toluene at a concentration of 5 $\mu\text{g/L}$. The fact that toluene has not been detected in other wells that are purged prior to sampling suggests that the potential sampling bias caused by leaching of the polyethylene sealant is minor because of reduced contact time under dynamic sampling conditions (Parker and Ranney [1998]) or a decrease in the amount of toluene leached from the sealant over time as the compound ages.

In any case, recent advancements in the design of the sampling ports use mechanical expansion plugs instead of the hot-melt polyethylene sealant (Solinst Canada Ltd. 2001). This will eliminate the need for the chemical sealant and potential biases associated with its use.

Sorption and Leaching of Metals and Other Inorganic Solutes

Previous studies indicate that while plastic tubing is generally inert with regard to anionic solutes, positively charged solutes are subject to cation exchange reactions (Ranney and Parker 1998). Several laboratory studies have been performed to evaluate the significance of these processes in ground water monitoring applications, however few quantitative studies have been performed using HDPE tubing. Results of the limited studies indicate that negative biases from sorption onto polymeric tubing is minor compared to stainless steel. Sorption and/or leaching of metals from the stainless-steel screens and clips used to construct the CMT wells may be of concern, however. To minimize these biases, the CMT well screens could be constructed with plastic mesh and plastic ties. Readers are referred to Parker et al. (1990), Hewitt (1992), Hewitt (1994), and Ranney and Parker (1998) for additional discussions of the applicability of using polymeric tubing for monitoring trace concentrations of dissolved metals and other ionic contaminants.

Suggested Sampling Protocol to Minimize Chemical Biases

Chemical biases caused by sorption/desorption and diffusion of dissolved hydrophobic organic contaminants through the CMT tubing can be minimized by thorough purging of each

channel prior to sampling and by collecting ground water samples from separate 0.25-inch (0.64 cm) diameter Teflon sampling tubing placed inside the channels to depths corresponding to the various intake ports. That way, ground water from the formation is drawn through the ports and immediately enters the Teflon sampling tubing where the sorption/diffusion of the solutes is reduced. Similarly, contact between the ground water sample and the CMT tubing could be minimized by using downhole canister samplers similar to those described by Pankow (1985) and Johnson (1987), although those samplers have not yet been tested with the CMT system.

Trial Installations

Canadian Forces Base Borden, Ontario, Canada

Two CMT multilevel wells (ME-1 and ME-2) were installed at Canadian Forces Base (CFB) Borden in Ontario, Canada. The CMT wells were installed in a well-studied part of the base where a controlled release of tetrachloroethylene (PCE) took place in 1991 (Brewster et al. 1995). During that experiment, 771 L of PCE were injected into a shallow sand aquifer isolated within a 9×9 m sheet pile enclosure. Sheet piles extended through the surficial aquifer into the underlying clay till aquitard.

The hydrogeology in the vicinity of the 9×9 m cell is well understood as a result of detailed field studies performed by Foley (1992) and Morrison (1998). In those investigations, more than 105 boreholes were drilled in and around the 9×9 m cell, into which more than 50 single- or multilevel monitoring wells were installed.

The study area is underlain by a 15-foot-thick (4.6 m) surficial sandy aquifer referred to as the Borden Aquifer (Figure 9). Unconfined ground water occurs within that unit at a depth ranging seasonally from 3 to 6 feet (0.9 to 1.8 m) bgs. A 20- to 28-foot-thick (6.1 to 8.5 m) clay aquitard unconformably underlies the upper aquifer in the study area, separating it from the underlying lower aquifer (Morrison 1998).

The clay aquitard can be divided into an upper and lower unit based on lithology and post-depositional weathering. The upper unit is ~10 to 15 feet (3.1 to 4.6 m) thick and is composed of silty clay containing discontinuous sandy laminae and thin sand interbeds. Vertical cracks and fissures are common in the upper unit because of erosion and desiccation following the Late Wisconsin glacial retreat. The lower part of the aquitard is ~6 to 10 feet (2 to 3 m) thick and is composed of unweathered, unfractured silty clay and clay. The Lower Aquifer in the vicinity of the 9×9 m cell is relatively thin, consisting of a 6- to 10-foot-thick (2 to 3 m) continuous layer of medium- to coarse-grained sand. Piezometric heads within the lower aquifer fluctuate between ~697 and 700 feet above sea level (asl; 212.5 and 213.4 m) in the last few years (Morrison 1998).

Detailed hydraulic head monitoring by Foley (1992) and Morrison (1998) showed a strong downward hydraulic gradient between the upper and lower aquifers. Hydraulic head profiles measured in 1996 in two piezometer clusters located near CMT wells ME-1 and ME-2 are shown in Figure 9. Piezometer cluster ML96-2 is located ~80 feet (24 m) northwest of CMT wells ME-1 and

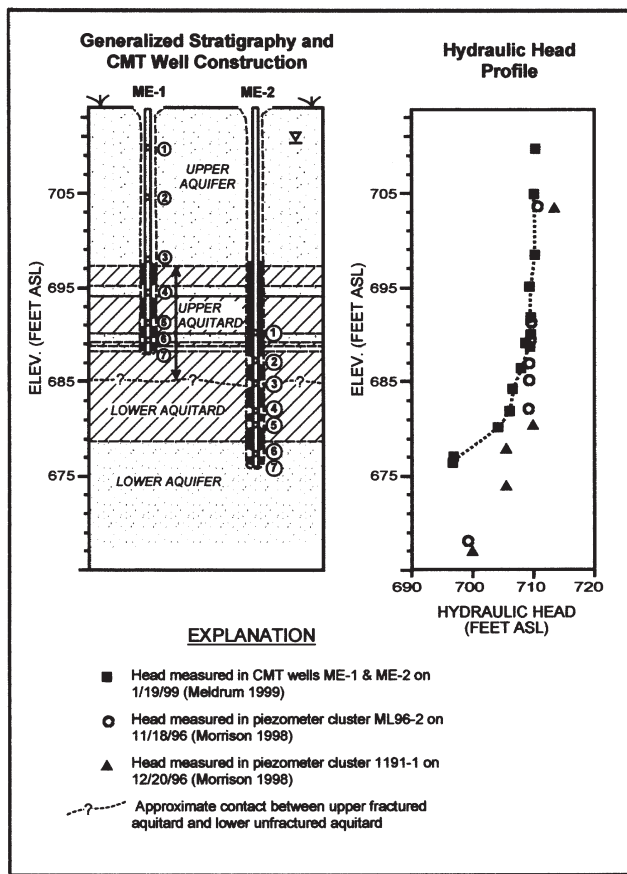

Figure 9. Generalized stratigraphy, well construction, and hydraulic head profile. CMT multilevel wells ME-1 and ME-2, Canadian Forces Base Borden, Ontario, Canada.

ME2. Piezometer cluster 1191-1 is ~40 feet (12 m) south of the two CMT wells. A head change in excess of 12 feet (3.6 m) was measured in 1996 between piezometers installed in the upper aquitard and the lower aquifer. Core logs and hydraulic head data from those and other piezometers suggest that nearly all of the head change occurs across the basal portion of the clay aquitard, where the sandy interbeds and vertical fractures are absent. The upper and middle portions of the clay aquitard are suspected of being hydraulically active (i.e., hydraulically connected to the upper aquifer) because of the abundance of coarse-grained interbeds and desiccation fractures (Morrison 1998).

CMT wells ME-1 and ME-2 were installed in June and December 1998, respectively, with a total of 14 ports in the upper and lower aquifers and in the intervening clay aquitard (Figure 9). The wells were installed in boreholes created with a dual-tube direct-push sampling system described by Einarson (1995). Continuous soil cores were collected and logged in detail prior to selecting the screened intervals of the multilevel wells. After the coring was finished, the sampling equipment was withdrawn from the boreholes, but the outer 3-inch (7.5 cm) inside-diameter (I.D.) drive casing was left in place to keep the boreholes from collapsing. The CMT wells were built aboveground according to the design, complete with sand packs and bentonite packers, and were then inserted into the boreholes inside of the steel drive casing. The steel casing was then withdrawn, allowing ground water to contact and hydrate the bentonite packers.

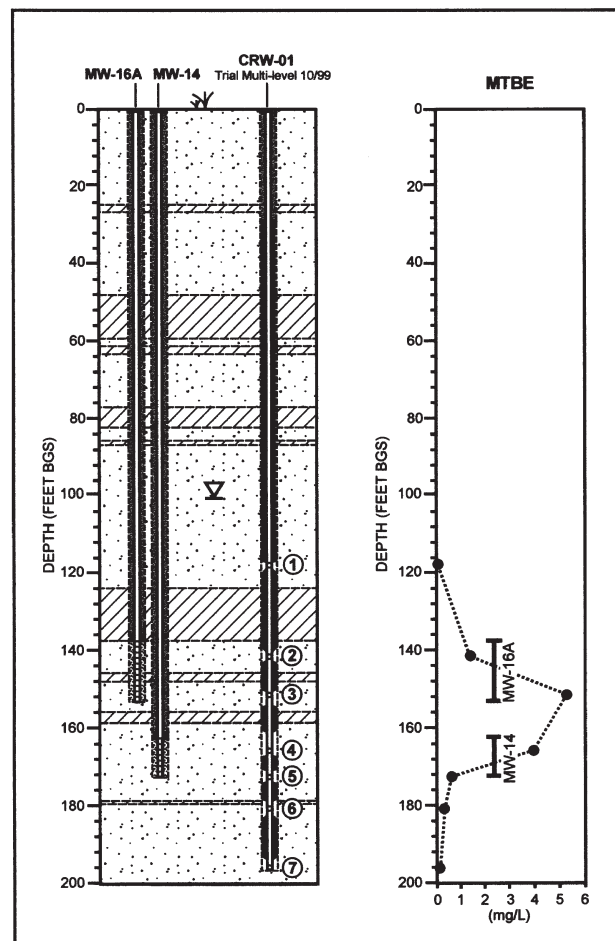

Figure 10. Construction details and MTBE concentration profile from a trial CMT multilevel well plotted next to data from two nearby conventional monitoring wells, Santa Monica, California.

As shown in Figure 9, the wells were constructed in a two-well pair with ME-1 monitoring the upper aquifer and the upper portion of the underlying clay aquitard. ME-2 was constructed to monitor the lower portion of the clay aquitard and the underlying lower aquifer. This multilevel well pair allowed measurement of the hydraulic head at 14 discrete depths, providing detailed definition of the hydraulic head distribution in the shallow geologic deposits next to the 9 × 9 m cell. After an equilibration period of one month, hydraulic heads had stabilized in the various channels.

Figure 9 shows the head distribution measured in the CMT wells on January 19, 1999, along with the CMT well construction and 1996 head measurements from the nearby piezometer clusters for comparison. Hydraulic head data from the CMT wells shows the same strong downward vertical pressure gradient measured by Morrison in the nearby piezometer clusters in 1996. As shown in Figure 9, there was a 13-foot (4 m) difference in head between the upper and lower aquifers measured in the CMT wells in early 1999, with most of the measured head change (7.3 feet [2.2 m]) occurring in the lower 3.3 feet (1 m) of the lower aquitard between the fifth and sixth sampling ports in CMT-2. The strong downward hydraulic gradient (2.2) across this thin zone supports the hypothesis that the lower unfractured portion of the lower aquitard is a strong barrier to downward ground water flow.

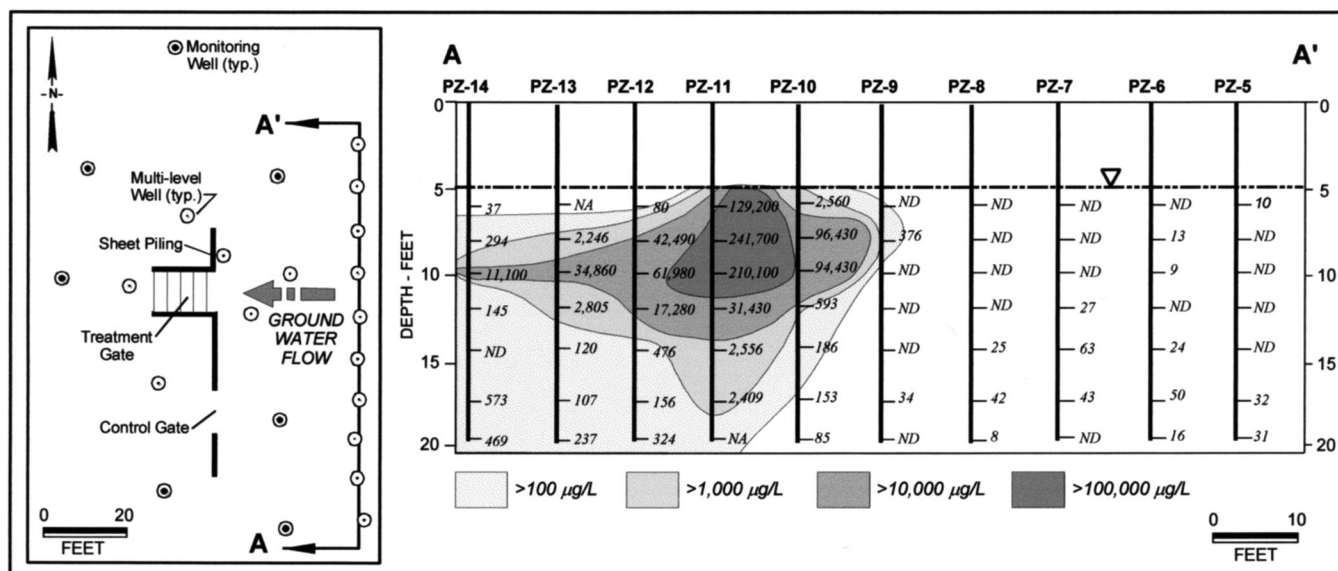

Figure 11. A stratified VOC plume at Alameda Point, California. Site plan shown on left. On right, transect A to A' (perpendicular to the direction of ground water flow) showing concentration contours of cis-1,2 DCE across the dissolved plume.

The head data from the CMT wells is comparable to the data from the nearby piezometer nests, although there are important differences. First, the hydraulic head measured in the CMT ports completed in the lower aquifer is ~3 feet (1 m) lower than the head measured by Morrison in 1996 using piezometers reportedly completed within the same unit. This difference is likely because the measurements were made almost three years apart (three feet of head fluctuation is within the range of head values historically measured within the unit in the vicinity of the 9 × 9 m cell [Morrison 1998]). Second, the strong drop in head recorded in the CMT wells at the base of the lower aquitard occurs more abruptly and at a higher elevation than in piezometer clusters ML96-2 and 1191-1. This is likely because of natural variation in the geology in the study area. Relatively high hydraulic heads are maintained to a greater depth 40 feet (12 m) south of the CMT wells near cluster 1191-1, suggesting that the lower aquitard extends to a greater depth there than in the vicinity of the CMT wells. Variations in the depth of the base of the aquitard is not unexpected; Morrison (1998) noted that the elevation of the base of the unit varied by more than 8 feet (2.4 m) in the study area. The same condition may be true 80 feet (24 m) to the northwest in the vicinity of piezometer cluster ML96-2, although the data there are inconclusive. As shown in Figure 9, the bottom two piezometers in the ML96-2 cluster are spaced >14 feet (4.3 m) apart vertically. Thus, there are an insufficient number of data points to show whether, and at what elevation, an abrupt drop in head (indicating the base of an unfractured aquitard) may occur or whether the pressure decrease may occur more gradually with depth, suggesting a thicker, more permeable (i.e., more extensively fractured) aquitard than in the vicinity of the CMT wells.

In summary, the much lower vertical hydraulic conductivity of the bottommost 3 feet (1 m) of the lower aquitard indicated by the detailed head profile in the CMT wells is consistent with the observed penetration of PCE down to but not through the base of the aquitard. The base of the aquitard in that area likely has few or perhaps no fractures. Only a head profile with many data points could have accurately identified this hydro-

geologic condition.

In June 1998, head measurements were again made in CMT wells ME-1 and ME-2. This time, however, the measured heads in well ME-2 were much different from the earlier measurements, suggesting that one or more of the lower seals had likely failed. The potential causes of the leakage could have been from one or more of the following:

- (1) A poor bond between the polyethylene sealant and the tubing caused by insufficient heating of the sealant
- (2) Deformation of the bentonite packers en route to the job site from the warehouse where the wells constructed
- (3) Slow dissolution of the bentonite packers when they are not completely surrounded by a porous medium (as may be the case in installations in boreholes drilled into aquitards or bedrock where the tops and bottoms of the packers contact only water in the borehole) (Einarson 2001).

Additional field testing of the bentonite packers is planned to determine which of these factors likely caused the packer failure at the Borden site.

Santa Monica, California

A trial multilevel well was installed in Santa Monica, California, in December 1999 to assess the feasibility of using CMT multilevel wells to monitor a dissolved plume of methyl tert butyl ether (MTBE) more than 120 feet (37 m) below the ground surface. The trial well was located within 20 feet (6 m) of a pair of 4-inch (10 cm) diameter conventional monitoring wells to compare the concentrations of MTBE in water samples collected from the CMT well with samples collected from the conventional wells. Continuous soil cores were first collected with a sonic drilling rig to a depth of 195 feet (60 m); 3.5-inch (9 cm) I.D. flush-threaded steel casing was advanced incrementally to keep the borehole open. The cores were logged in detail to identify preferred pathways of contaminant migration. The well was built completely aboveground and inserted into the borehole prior to removing the steel casing. The well was developed (using the gas lift/vacuum extraction method described earlier) and samples were collected at a rate of 120 mL/min using a 0.25-inch (0.64 cm) O.D. Teflon iner-

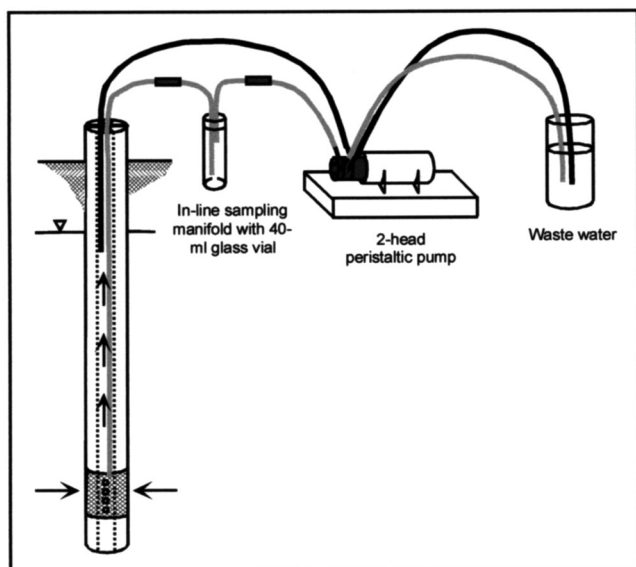

Figure 12. Dual-tube ground water sampling apparatus.

tial lift pump (Solinst Canada Ltd., Georgetown, Ontario, Canada).

A summary of the stratigraphy and construction of the CMT well and the nearby conventional monitoring wells is shown in Figure 10. A graph of MTBE concentrations versus depth for all three wells is shown on the right of the figure. Comparison of the MTBE concentrations measured in samples from the CMT well with data from the conventional wells provides an example of contaminant mixing in monitoring wells described earlier. It is clear from the figure that wells MW-14 and MW-16 yield ground water samples that are a composite of ground water within the vertical interval of the aquifer screened by the wells. Analysis of a sample from Zone 3 of the CMT well shows that MTBE is present in the aquifer at concentrations as high as 5300 $\mu\text{g/L}$. However, the concentration of MTBE measured in samples from the conventional wells is much lower (~ 2300 $\mu\text{g/L}$) because relatively clean water (entering the upper portion of MW-16's well screens and the lower portion of MW-14's well screens) mixes with the water containing high concentrations of MTBE when these wells are pumped.

Alameda Point, California

A transect of 10 CMT multilevel monitoring wells was installed at Site 1, Alameda Point (formerly Alameda Naval Air Station), California, during the course of a three-year University of Waterloo field experiment to treat a mixed plume of VOCs and petroleum hydrocarbons in situ using a sequential reactive barrier (Morkin et al. 1998; Fiorenza et al. 2000).

Because the aquifer consists of loose unconsolidated sand, the multilevel wells could be installed by simply inserting the CMT tubing and well screens into small-diameter steel drive casing that had been vibrated with a knockout plug to the bottom of the aquifer (22 feet [6.7 m] bgs). After each multilevel well was inserted, the drive casing was removed, allowing the native sand to collapse around the drive casing.

Figure 11 shows concentration contours of cis-1,2 DCE along the transect of monitoring wells collected in December 1998. A high-strength plume core, exhibiting concentrations of cis-1,2 DCE $>300,000$ $\mu\text{g/L}$, was mapped in the upper

portion of the aquifer in the vicinity of well PZ-11. The plume core is surrounded by ground water having as much as three orders of magnitude lower concentrations of dissolved VOCs. The large variation in concentrations of dissolved VOCs in a single multilevel well over vertical distances of just a few feet provides evidence that there is no enhanced hydraulic interconnection between the intake ports.

The Alameda Point VOC plume provided an opportunity to test the hypothesis that sampling biases could be minimized by thoroughly purging the various channels prior to sampling and collecting ground water samples from separate Teflon sampling tubing inserted to the bottom of each CMT channel. These techniques were followed when collecting all of the samples from the multilevel wells at Alameda Point. In addition, one well (PZ-14D, located next to well PZ-14) was constructed with separate stainless-steel "control" sampling tubing to further assess potential sampling biases associated with the new CMT monitoring system. Stainless steel is much less affected by sorption/desorption of organic compounds than polymeric tubing. Therefore, it was thought that samples collected from the stainless-steel tubing would yield independent values of dissolved solute concentrations in the aquifer that were not biased by processes affecting the polymeric tubing. When constructing well PZ-14D, 0.13-inch (3.3 mm) O.D. stainless-steel tubing was secured to the outside of the multi-channel tubing. Seven lengths of tubing were attached, each one extending to the depth of one of the ports of the multilevel monitoring well. The ends of the stainless steel tubing were wrapped in a fine stainless-steel mesh, allowing for the independent collection of ground water samples from the aquifer at the same depths as the ports in the CMT multilevel well.

Well PZ-14D Sampling Technique

Ground water samples were collected from the Teflon sampling tubing and the stainless-steel control tubing using a peristaltic pump. To minimize potential sampling biases caused by stagnant water in the various CMT channels, a dual-tube water sampling technique was employed. In addition to the sampling tubing described previously, separate lengths of 0.25-inch (0.64 cm) O.D. polyethylene "purge tubing" were inserted into each CMT channel 3 feet (0.9 m) below the static ground water depth (i.e., to a depth of approximately 8 feet [2.4 m] bgs). Water was then simultaneously pumped from the shallow purge tubing and the deeper sampling tubing (either the Teflon or stainless steel tubing) in each channel using a dual-head peristaltic pump (Figure 12). By doing this, stagnant water above the CMT intake ports was drawn upward, away from the intake of the Teflon or stainless-steel sampling tubing. Ground water entering the CMT sampling ports was immediately drawn into the deeper sampling tubing, thus minimizing contact with the HDPE CMT tubing.

Samples of the stagnant water in the various channels were collected from the first 40 mL of water pumped from the upper purge tubing. This was done to test the hypothesis that VOCs present at shallow depths in the aquifer may have diffused into channels monitoring deeper zones during the eight-month period since the wells were last sampled. Ground water samples were then collected from each length of the stainless-steel control tubing and the 0.25-inch (0.64 cm) Teflon sampling tubing after ~ 750 mL of water had been purged and elec-

Table 1
Concentrations of Select VOCs and Petroleum Hydrocarbons in Samples Collected from CMT
Well PZ-14D, June 7, 1999, Alameda Point, California

CMT Port Depth (feet bgs)	Sample ID	Vinyl Chloride	cis 1,2 DCE	trans 1,2 DCE	Benzene	Toluene	Ethylbenzene	p/m Xylenes
		log Kow: 0.6 ^a	1.86 ^b	2.09 ^b	2.13 ^a	2.69 ^a	3.15 ^a	3.2 ^c
8	Pz14D-2 purge water	101.0	134.8	14.7	21.7	255.7	67.6	109.3
	PZ14D-2 CMT channel*	<44	<5.4	67.1	58.4	106.9	167.1	443.9
	PZ14D-2 control**	<44	<5.4	62.4	54.1	109.7	131.4	444.3
	% of control	NA	NA	107.53%	107.95%	97.45%	127.17%	99.91%
10	PZ14D-3 purge water	307.8	341.3	<1	25.7	171.5	11.6	31.6
	PZ14D-3 CMT channel	1904.0	1078.0	75.1	46.2	1397.0	235.7	989.1
	PZ14D-3 control	1607.0	744.9	85.2	100.4	1338.0	227.8	970.3
	% of control	118.48%	144.72%	88.15%	46.02%	104.41%	103.47%	101.94%
12	PZ14D-4 purge water	452.6	847.89	<1	26.8	243.6	11	31.4
	PZ14D-4 CMT channel	517.7	3627.0	114.4	134.4	325.8	186.7	629.1
	PZ14D-4 control	563.7	3953.0	69.9	118.7	361.5	154.4	577.2
	% of control	91.84%	91.75%	163.66%	113.23%	90.12%	120.92%	108.99%
14.5	PZ14D-5 purge water	466.2	862.0	<1	24.7	160.3	13.1	16.9
	PZ14D-5 CMT channel	<44	<5.4	<1	<3.8	<4.0	<2.5	<5.4
	PZ14D-5 control	<44	<5.4	<1	<3.8	<4.0	<2.5	<5.4
	% of control	NA	NA	NA	NA	NA	NA	NA
17.5	PZ14D-6 purge water	488.8	721.8	<1	25.8	165.6	<2.5	18.1
	PZ14D-6 CMT channel	217.1	341.2	<1	<3.8	<4.0	<2.5	<5.4
	PZ14D-6 control	497.7	526.5	<1	<3.8	<4.0	<2.5	<5.4
	% of control	43.62%	64.81%	NA	NA	NA	NA	NA
20	PZ14D-7 purge water	534.4	706.5	<1	21.1	130.2	25	50.7
	PZ14D-7 CMT channel	3368.0	661.8	<1	<3.8	<4.0	<2.5	<5.4
	PZ14D-7 control	2143.0	1159.0	<1	<3.8	<4.0	<2.5	<5.4
	% of control	157.16%	57.10%	NA	NA	NA	NA	NA

(All concentrations in µg/L)

* = sample collected from Teflon tubing inserted to bottom of CMT channel

** = sample collected from stainless tubing secured to outside of CMT well and extending to same depth as CMT intake port

NA = Not applicable, one or both values at or below method reporting limit

a = Schwartzbach et al. 1993

b = Mabey et al. 1982

c = Tewari et al. 1982

trical conductivity (EC) measurements had stabilized. Samples were collected in 40 mL glass vials positioned upstream of the peristaltic pump. All samples were spiked with sodium azide to minimize aerobic biodegradation of the organic compounds and were shipped on ice to the University of Waterloo analytical laboratory in Ontario, Canada.

Analytical Method

All VOCs were analyzed at University of Waterloo's analytical laboratory by the headspace technique using a Varian Genesis autosampler and a Hewlett-Packard 5890 gas chromatograph equipped with a split injection port 12:1 at 150°C, and a capillary column DB-VRX 30 m × 0.32 mm I.D., maintained isothermally at 32°C. Helium was used as the carrier gas at a flow rate of 3.5 mL/min, and a photoionization detector (PID) was used with an 11.7 eV lamp. A complete list of analytes and associated method reporting limits is presented by Einarson (2001).

Results

Table 1 presents a summary of analytical results for VOCs in samples collected from multilevel well PZ-14D in June

1999. Octanol-water partition coefficients (K_{ow}) are also listed for each compound shown. Compounds with higher K_{ow} values are more hydrophobic and would be expected to diffuse more rapidly through the walls of the CMT tubing as discussed earlier. Those compounds could also preferentially sorb to the inside walls of the CMT tubing, resulting in a potential negative bias.

As shown in Table 1, many VOCs were detected in samples of purge water from channels monitoring deeper portions of the aquifer (i.e., below the high-strength core of the VOC plume) but were not detected in samples collected from the corresponding stainless-steel or Teflon sampling tubing after purging was complete. This indicates that VOCs detected in the purge water from those channels likely resulted from diffusion of VOCs from adjacent channels or from the contaminant plume directly. This positive bias was effectively removed by purging the stagnant water from the channels prior to sampling and collecting the samples from separate sampling tubing inserted to the full depth of the various CMT channels.

No aromatic hydrocarbons were detected in samples collected from either the stainless-steel or Teflon sampling tubing below a depth of 12 feet (3.7 m). *Cis*-1,2 DCE and vinyl chloride, however, were detected in the Teflon and stainless-

steel tubing near the bottom of the aquifer (i.e., the channels monitoring ground water at depths of 17.5 and 20 feet [5.4 and 6.1 m] bgs). The fact that these compounds were detected in samples collected from the Teflon sampling tubing at concentrations higher than those measured in samples of the purge water suggests that the VOCs are present near the base of the aquifer, beneath the core of the VOC plume, and are not artifacts of diffusion through the CMT tubing. Measurement of high concentrations of *cis*-1,2 DCE and vinyl chloride in samples from the stainless-steel control tubing at the same depths supports that conclusion.

Overall, there is a reasonably good match between the concentrations of VOCs measured in most of the samples collected from the CMT channels and the stainless-steel control tubing. In some cases, concentrations of VOCs were higher in samples collected from the stainless-steel control tubing than the samples collected from the CMT channels (e.g., *cis*-1,2 DCE measured in samples from depths of 17.5 and 20 feet [5.4 and 6.1 m]). This may be evidence of a negative sampling bias caused by inadequate flushing of water through the Teflon sampling tubing prior to sample collection. As discussed previously, sorption of hydrophobic solutes onto virgin Teflon sampling tubing can decrease the concentration of organic solutes in the samples initially collected from the tubing. In several instances, the concentrations of VOCs were higher in the samples collected from the Teflon sampling tubing than the samples from the stainless-steel control tubing. This may be evidence of a negative bias in samples collected from the stainless-steel control tubing because of degassing during sample collection. The tips of the stainless-steel control tubing are wrapped with a very fine stainless-steel mesh to prevent sand from clogging the ends of the tubing. The fine mesh likely causes a significant head loss from friction when the stainless-steel tubing was being pumped. Thus, a larger vacuum was applied to collect ground water samples from the stainless-steel control tubing than the larger CMT channels. Alternatively, the differences between solute samples collected from the CMT channels (i.e., the Teflon sampling tubing) and the stainless-steel "control" tubing could be primarily a result of microscale variations in the distribution of dissolved contaminants surrounding the multilevel monitoring well. As discussed, the aquifer near well PZ-14D exhibits striking variability in the concentration and spatial distribution of dissolved VOCs. In fact, DNAPL was sampled in a CMT multilevel well 30 feet (9 m) away from well PZ-14D during a later sampling event. Therefore, because of the documented variability in the actual concentration of the various solutes in the aquifer surrounding well PZ-14D, the designation of samples from the stainless-steel tubing as "control" samples should be viewed with caution. Similar testing and comparisons performed in a laboratory setting would likely provide a more rigorous evaluation of the potential biases associated with the various methods of sampling CMT multilevel monitoring wells.

Cost

To gain widespread use, installations of multilevel monitoring systems must be less expensive than other methods for permanent depth-discrete ground water monitoring, e.g., clusters of conventional monitoring wells. The price of the

CMT well materials is comparable to the materials used to construct conventional monitoring wells: The current price for the CMT tubing ranges from US\$3.95 to \$6.50 per linear foot. (depending on volume purchased [Solinst Canada Ltd. 2001]), a cost similar to 2-inch (5 cm) or 4-inch (10 cm) diameter slotted PVC pipe. Aside from the CMT tubing, all other components are off-the-shelf materials commonly used in environmental investigations (e.g., stainless-steel mesh, sand, and bentonite pellets).

The real cost savings, of course, are apparent when the cost of drilling and installing one CMT well is compared to the cost of drilling and installing seven individual monitoring wells. Drilling footage, well materials, and disposal of investigation-derived waste (i.e., drill cuttings) is reduced sevenfold. More time is needed to construct a seven-zone CMT well than a conventional single-zone monitoring well; however, experience shows that building a CMT well using either conventional (tremie) methods or with seals made of bentonite packers takes about twice the time as constructing a conventional monitoring well to the same depth.

Conclusions

The CMT multilevel monitoring system represents a new low-cost multilevel monitoring system that can be installed with a variety of drilling equipment to depths currently greater than 250 feet (76 m). Continuous multichannel HDPE tubing eliminates the potential for leakage at joints (because there are no joints) and contributes to the low cost of the system. Compared to nested monitoring wells, having only one tube in a borehole simplifies the installation of sand packs and annular seals, which can be installed from the surface using conventional tremie methods. Bentonite packers and prepacked sand packs have also been developed that are attached to the tubing at the ground surface. Fully built multilevel wells are then inserted into boreholes in unconsolidated sediments through steel drive casing or in open holes in bedrock in just a few minutes. Aboveground construction is feasible because the CMT tubing is flexible enough to be lowered hand-over-hand into a borehole. Aboveground construction ensures that the sand packs and seals are located at precisely the desired depths, a goal that is sometimes not met when sand and bentonite tablets are poured from the surface or via a tremie pipe. Additional field testing and monitoring of the bentonite packer seals is needed, however, to assess the long-term viability of the seals in a variety of hydrogeologic settings.

Like all ground water monitoring devices, there are biases inherent with the CMT multilevel system. The design of the system requires that the tubing be flexible so that it can be inserted hand-over-hand into a borehole. There are several types of flexible polymeric tubing, but HDPE was selected as the optimum material because of its favorable working characteristics and low cost. For many target contaminants, HDPE is susceptible to both positive and negative biases caused by sorption, desorption, and diffusion. These biases can be minimized by purging the channels prior to sampling and collecting samples from separate 0.25-inch (0.64 cm) diameter Teflon sampling tubing or canister samplers placed to the bottom of each sampling channel adjacent to the various ports. In this way, ground water samples are collected that have minimal

contact with the HDPE CMT tubing. Evaluations of the CMT system performed to date have focused on VOCs, but it is expected that with appropriate sampling methods, the system can be used to collect viable samples of ground water containing other dissolved contaminants. Also, additional evaluations of other sampling methods and pumps should be undertaken, ideally in a laboratory setting. Additional studies should include evaluations of small-diameter canister samplers and other types of small-diameter pumps that are currently being developed for the system.

Acknowledgments

Funding for the development and testing of the CMT system was provided by (1) Precision Sampling Inc., Richmond, California, (2) Conor Pacific/EFW, Palo Alto, California, (3) the University Consortium Solvents-In-Groundwater Research Program, and (4) Solinst Canada Ltd. Solinst Canada is the exclusive licensee of the CMT system. The authors are grateful to the U.S. Navy, U.S. Air Force, the Charnock Regional Assessment Group, and Defence Canada for providing sites to test the CMT technology. The authors would also like to thank Doug Mackay, Jim Barker, Rick Devlin, Don Winglewich, Rob Dobush, Gary Soden (Clear Heart Drilling), Bob Ingleton, and Paul Johnson for their technical assistance and support, Resonant Sonic International for their considerable in-kind support, and Denise Mason and Kate Motroni for their technical graphics. Finally, we thank James Martin-Hayden and two anonymous reviewers for their thoughtful comments that greatly improved the quality of this article.

Authors' Note: Since the completion of the field trials described in this paper, a number of modifications to the system have been implemented, or are pending, for the commercial versions now available on the market. These evolutions principally relate to the channel seal methodology and to the tools and sampling options available.

Editor's Note: The use of brand names in peer-reviewed papers is for identification purposes only and does not constitute endorsement by the authors, their employers, or the National Ground Water Association.

References

Barcelona, M.J., J.A. Helfrich, and E.E. Garske. 1985. Sampling tubing effects on ground water samples. *Analytical Chemistry* 57, 460-464.

Barker, J.F., G.C. Patrick, L. Lemon, and G.M. Travis. 1987. Some bases in sampling multilevel piezometers for volatile organics. *Ground Water Monitoring Review* 7, no. 2: 48-54.

Barrow, J.C. 1994. The resonant sonic drilling method: An innovative technology for environmental restoration programs. *Ground Water Monitoring & Remediation* 14, no. 2: 153-160.

Black, W.H., and F.D. Patton. 1986. Multiple-level ground water monitoring with the MP system. Paper presented at Surface and Borehole Geophysical Methods and Ground Water Instrumentation Conference and Exposition, October 15-17, 1986, in Denver, Colorado. Dublin, Ohio: National Water Well Association.

Brewster, M.L., A.P. Annan, J.P. Greenhouse, B.H. Kueper, G.R. Olhoef, and J.D. Redman. 1995. Observed migration of a controlled DNAPL release by geophysical methods. *Ground Water* 33, no. 6: 977-987.

Butler, J.J. 2001. University of Kansas Geological Survey. Personal communication.

Cherry, J.A., R.W. Gillham, E.G. Anderson, and P.E. Johnson. 1983. Migration of contaminants in groundwater at a landfill: A case study: 2. Groundwater monitoring devices. *Journal of Hydrology* 63: 31-49.

Cherry, J.A., and P.E. Johnson. 1982. A multilevel device for monitoring in fractured rock. *Ground Water Monitoring Review* 2, no. 3: 41-44.

Curran, C.M., and M.D. Tomson. 1983. Leaching of trace organics into water from five common plastics. *Ground Water Monitoring Review* 3, no. 3: 68-71.

Einarson, M.D. 1995. EnviroCore: A new dual-tube direct push system for collecting continuous soil cores. Paper presented at 9th National Outdoor Action Conference, May 8-12, 1995, Las Vegas, Nevada. Columbus, Ohio: National Ground Water Association.

Einarson, M.D. 2001. A new, low-cost multi-level monitoring system. M.S. thesis, Department of Earth Sciences, University of Waterloo, Ontario Canada.

Fiorenza, S., C.L. Oubre, and C.H. Ward. 2000. *Sequenced Reactive Barriers for Groundwater Remediation*. Boca Raton, Florida: Lewis Publishers.

Foley, S. 1992. Influence of sand microbeds on hydraulic response of an unconfined clay aquitard. M.S. thesis, Department of Earth Sciences, University of Waterloo, Ontario Canada.

Garabedian, S.P., D.R. LeBlanc, L.W. Gelhar, and M.A. Celia. 1991. Large-scale natural gradient tracer test in sand and gravel, Cape Cod, Massachusetts: II. Analysis of spatial moments for a non-reactive tracer. *Water Resources Research* 27, no. 5: 911-924.

Gillham, R.W. 1989. Selection of casing materials for groundwater monitoring wells—Sorption processes. Paper presented at NSWMA Waste Tech 1989, October 23, 1989. Washington, D.C.: National Solid Waste Management Association.

Gillham, R.W., and S.F. O'Hannesin. 1990. Sorption of aromatic hydrocarbons by materials used in construction of monitoring wells. In *Ground Water and Vadose Zone Monitoring*, ASTM STP 1053. Philadelphia: American Society for Testing and Materials.

Hewitt, A.D. 1992. Potential of common well casing materials to influence aqueous metal concentrations. *Ground Water Monitoring Review* 12, no. 2: 131-136.

Hewitt, A.D. 1994. Dynamic study of common well screen materials. *Ground Water Monitoring & Remediation* 14, no. 1: 87-94.

Johnson, R.L., J.F. Pankow, and J.A. Cherry. 1987. Design of a ground-water sampler for collecting volatile organics and dissolved gases in small-diameter wells. *Ground Water* 25, no. 4: 448-454.

Junk, G.A., H.J. Svec, R.D. Vick, and M.J. Avery. 1974. Contamination of water by synthetic polymer tubes. *Environmental Science & Technology* 8, no. 11: 1100-1106.

LeBlanc, D.R., S.P. Garabedian, K.M. Hess, L.W. Gelhar, R.D. Quadri, K.G. Stollenwerk, and W.W. Wood. 1994. Large-scale natural gradient tracer test in sand and gravel, Cape Cod, Massachusetts: I. Experimental design and observed tracer movement. *Water Resources Research* 27, no. 3: 893-910.

Mabey, W.R., J.H. Smith, R.T. Podoll, H.L. Johnson, T. Mill, T.-W. Chou, J. Gates, I.W. Partridge, H. Jaber, and D. Vandenberg. 1982. Aquatic fate process data for organic priority pollutants. Final report: Office of regulations and standards. U.S. EPA Report-440/4-81-014.

- Mackay, D.M., W.P. Ball, and M.G. Durant. 1986a. Variability of aquifer sorption properties in a field experiment on groundwater transport of organic solutes: Methods and preliminary results. *Journal of Contaminant Hydrology* 1, 119-132.
- Mackay, D.M., J.A. Cherry, D.L. Freyberg, and P.V. Roberts. 1986b. A natural gradient experiment on solute transport in a sand aquifer: 1. Approach and overview of plume movement. *Water Resources Research* 22, no. 13: 2017-2029.
- Martin-Hayden, J.M., G.A. Robbins, and R.D. Bristol. 1991. Mass balance evaluation of monitoring well purging: II. Field tests at a gasoline contamination site. *Journal of Contaminant Hydrology* 8, 225-241.
- Meldrum, C.I. 1999. Use of a new multi-level monitoring system for determining hydraulic head distribution in the Borden Aquitard. B.S. thesis, Department of Earth Sciences, University of Waterloo, Ontario, Canada.
- Morkin, M.I., J.F. Barker, J.F. Devlin, and M. McMaster. 1998. In-situ sequential treatment of a mixed organic plume using granular iron, O₂, and CO₂ sparging. Paper presented at First International Conference on Remediation of Chlorinated and Recalcitrant Compounds, May 18-21, 1998, Monterey, California. Columbus, Ohio: Battelle Press.
- Morrison, W.E. 1998. Hydrogeologic controls on flow and fate of PCE DNAPL in a fractured and layered clayey aquitard: A Borden experiment. M.S. thesis, Department of Earth Sciences, University of Waterloo, Ontario, Canada.
- Pankow, J.F., L.M. Isabelle, J.P. Hewetson, and J.A. Cherry. 1985. A tube and cartridge method for downhole sampling for trace organics in ground water. *Ground Water* 23, no. 5: 775.
- Parker, L.V. 1994. The effects of ground water sampling devices on water quality: A literature review. *Ground Water Monitoring & Remediation* 14, no. 2: 130-141.
- Parker, L.V., A.D. Hewitt, and T.F. Jenkins. 1990. Influence of casing materials on trace-level chemicals in well water. *Ground Water Monitoring Review* 10, no. 2: 146-156.
- Parker, L.V. and T.A. Ranney. 1997. Sampling trace-level organic solutes with polymeric tubing: I. Static studies. *Ground Water Monitoring & Remediation* 17, no. 4: 115-124.
- Parker, L.V., and T.A. Ranney. 1998. Sampling trace-level organic solutes with polymeric tubing: 2. Dynamic studies. *Ground Water Monitoring & Remediation* 18, no. 1: 148-155.
- Pickens, J.F., J.A. Cherry, G.E. Grisak, W.F. Merritt, and B.A. Risto. 1978. A multilevel device for ground water sampling and piezometric monitoring. *Ground Water* 16, no. 5: 322-327.
- Ranney, T.A., and L.V. Parker. 1998. Comparison of fiberglass and other polymeric well casings: Part III. Sorption and leaching of trace-level metals. *Ground Water Monitoring & Remediation* 18, no. 3: 127-133.
- Rannie, E.H. and R.L. Nadon. 1985. An inexpensive, multi-use, dedicated pump for ground water monitoring wells. *Ground Water Monitoring Review* 8, no. 4: 100-107.
- Reinhard, M., N.L. Goodman, and J.F. Barker. 1984. Occurrence and distribution of organic chemicals in two landfill leachate plumes. *Environmental Science & Technology* 18, 953-961.
- Robbins, G.A. 1989. Influence of purged and partially penetrating monitoring wells on contaminant detection, mapping, and modeling. *Ground Water* 27, no. 2: 155-162.
- Robbins, G.A., and J.M. Martin-Hayden. 1991. Mass balance evaluation of monitoring well purging: I. Theoretical models and implications for representative sampling. *Journal of Contaminant Hydrology* 8, 203-224.
- Robertson, W.D., J.A. Cherry, and E.A. Sudicky. 1991. Ground water contamination from two small septic systems on sand aquifers. *Ground Water* 29, no. 1: 82-92.
- Schwartzbach, R.P., P.M. Gschwend, and D.M. Imboden. 1993. *Environmental Organic Chemistry*. New York: John Wiley & Sons.
- Solinst Canada Ltd. 2001. Personal communication.
- Tewari, Y.B., M.M. Miller, S.P. Wasik, and D.E. Martine. 1982. Aqueous solubility and octanol-water partition coefficient of organic compounds at 25 degrees C. *Journal of Chemical Engineering Data* 27, 451-154.
- U.S. Environmental Protection Agency. 1986. RCRA ground-water monitoring technical enforcement guidance document, OSWER-9950.1. Office of Waste Programs Enforcement, Office of Solid Waste and Emergency Response, Washington D.C.
- van der Kamp, G., L.D. Luba, J.A. Cherry, and H. Maathuis. 1994. Field study of a long and very narrow contaminant plume. *Ground Water* 32, no. 6: 1008-1016.

Biographical Sketches

Murray D. Einarson (*Einarson & Associates, 3806 El Centro Ave., Palo Alto, CA 94306; [650] 494-0946*) is a consulting hydrogeologist based in Palo Alto, California. His work focuses on developing innovative and more effective ways to characterize and remediate plumes of dissolved contaminants.

John A. Cherry is a professor at the University of Waterloo (200 University Ave. W., Waterloo, ON N2L 3G1 Canada; [519] 885-1211). His research for the last 25 years has focused on field studies of ground water contamination, including the integration of field information with laboratory and modeling studies for assessment of site contamination and remedial options.